

Fuzzy controller Design of servo system

Hitham Karim Ali Diyala University – College of Engineering
Amjad Jalil Ahmidi University of Technology
Saad Abdul Majeed Diyala University – College of Engineering

Abstract

In the past few years, fuzzy-rule-based modeling has become an active research field because of its good merits in solving complex nonlinear system identification and control problems.

A servo system (SS) is a class of a nonlinear position system that needs to be positioned accurately and fastly on a commanded position. The strategy followed in this paper in designing digital controller for such system is as follows:

- 1. Building a neuro-model that represents the open loop servo system. This is accomplished by sufficiently collecting input-output data and used it off-line to build the neural network that will represent the plant for the second design stage.*
- 2. Design fuzzy controller through simulation to reach the required closed –loop behavior.*

The design technique is based on the adjustment of the scale factors, rule base and membership functions of the controller was accomplished by fine tuning and heuristic corrections linked to the knowledge of the process to be controlled. For the specified plant, there are certain parameters, which achieved a well-controlled response.

الملخص:

أصبحت النمذجة المعتمدة على استخدام قواعد البيانات الضبابية (*fuzzy rule base*) من المجالات الفعالة وذلك بسبب مميزاتها الجيدة في حل معضلات السيطرة والتعرف على معالم المنظومة غير خطية. أن منظومة المؤازرة هي نوع من أنواع المنظومات الغير خطية والتي تتطلب السيطرة على خرج المنظومة الموقع المطلوب بدقة وسرعة عالية. إن الاستراتيجية المعتمدة في هذا

البحث لتصميم المسيطر الرقمي الضبابي (*digital fuzzy logic controller*) للسيطرة على منظومة المؤازر تعتمد على:
أولاً: بناء نموذج عصيبي (*neuro-model*) والذي يمثل المنظومة المؤازرة المفتوحة (*open-loop s.s*) ويتطلب ذلك معرفة بيانات الإدخال والإخراج لتلك المنظومة، حيث تستخدم تلك البيانات لبناء شبكة عصبية منفصلة (*off-line*) لتمثيل المنظومة (*plant*) لمرحلة التصميم اللاحقة.
ثانياً: تصميم المسيطر الضبابي من خلال التمثيل باستخدام الحاسوب للحصول على الاستجابة المطلوبة للدائرة المغلقة (*closed-loop*). تعتمد تقنية التصميم على تنظيم عوامل القياس (*scale factors*) والدوال العضوية (*membership functions*) للمسيطر الذي تم بناءه باستخدام التنعيم الدقيق والتصحيحات المؤرخة (*heuristic corrections*) المرتبطة بمعرفة النظام المراد السيطرة عليه. ومن الجدير بالذكر ان لكل منظومة هناك معلمات خاصة تحقق الاستجابة المطلوبة.

Fuzzy logic controller

1. Introduction:

Increasing, control systems are required to have dynamical performance and robust behaviors, yet are expected to cope with more complex, uncertain and highly nonlinear dynamic processes. Along with this increased process complexity is increased abstraction and uncertainty in the models and their mathematical representation. One significant approach in dealing with major changes and uncertainty in nonlinear dynamical processes is through intelligent modeling and control. Intelligent controllers are generally self-organizing or adaptive and are naturally able to cope with the significant changes in the plant and its environment, while satisfying the control design requirement [1]. As with any advanced control theory, a central issue is the representation and development of appropriate process models with known approximation errors. As processes increase in complexity, they become less amenable to direct mathematical modeling based on physical law, since they may be [2]:

- Distributed, stochastic, nonlinear and time varying.*
- Subject to large unpredictable environmental disturbances.*
- Have variables that are difficult to measure, have unknown casual relationships or are expensive to be evaluated in real time.*

The conventional controllers encounter difficulties when facing nonlinear, uncertain, temporal behaviour. In recent years, a great deal of attention has been paid to the application of Artificial Neural Networks (ANN) in modeling, identification, and control of dynamic processes [3]. ANNs provide an excellent mathematical tool for dealing with nonlinear problems. They have an important property, according to which nearly any continuous nonlinear relationship can be approximated with acceptable accuracy using a neural network with suitable architecture and weight parameter. There is another attractive property is the self-learning ability. A neural network (NN) can extract the system feature from historical training data using the learning algorithm, requiring a little or no a prior knowledge about the process. This provides modeling of nonlinear system a great flexibility. These features allow one to design adaptive control system for complex, unknown and nonlinear dynamic process [4].

As opposed to many effective applications, e.g. in pattern recognition problems, approximation of the nonlinear function, the application of NN in control systems requires taking into consideration the dynamic of the processes being investigated. Another important application area, where the dynamic NN can be effectively used, is diagnostics of industrial process [3].

Recently, fuzzy logic controllers (FLCs) are finding increasing use in industry. The application of fuzzy reasoning to process control has opened up a new approach in this field. A controller is built from a set of fuzzy rules naturally incorporate commonsense expert knowledge, it may be easier to build and to maintain this than a conventional controller [5].

The advantage of fuzzy control lies in its ability to implements the action of expert operator without the need of accurate mathematical model. The main benefits of this approach can be summarized as set below: [6,7]

- 1. It is a technique from the field of artificial intelligence (AI), which can be usefully employed to control a complex, nonlinear dynamic plant.*

2. Fuzzy controller are more robust than Proportional Integral Derivative (PID)

controllers because they can cover a much wider range of operating conditions

than PID can, and can operate with noise and disturbances of different natures.

3. Developing a fuzzy controller is cheaper than developing a model based or other

controller to be the same thing.

4. Fuzzy controllers are customizable since it is easier to understand and modify their rules, which not only use a human operator's strategy but also are expressed in natural linguistic terms.

5. It is easy to learn how fuzzy controllers operate and how to design and apply them to a concrete application.

The main objective of this work is to design and implementation of fuzzy logic controller to the servo system. The work is directed towards the following points:

1. To identify the servo system by the neural method MRNN
2. Using the neuro-identified model to design the fuzzy logic controller.
3. Testing the performance of the proposed design on the servo system.

2. System identification:

In general, exciting the system and observing its input and output over a time interval performs an identification experiment. These signals are normally recorded using computer with mass storage. The first step is to determine an appropriate form of the model and in the second step some statically based method is used to estimate the unknown parameter of the model. Finally the model obtained is tested to see whether it is an appropriate representation of the system [8].

The position system under experiment for collecting the input-output data depends on the feedback principle that the comparison of the controlled variable, whatever it may be with a desired value of that variable, so that an error signal or a measure of the error, can be formed. The servo is so arranged that operate in a sense to reduce the

error to zero so that the output equal the demanded input. The objective of the servomechanism is to position a massive object by means of a motor and gearbox.

The performance of RLS and MRNN for system identification will be examined, by considering the input output data collection from the plant.

The parallel identification scheme, which is used for identification, based on modified recurrent neural network (MRNN) is illustrated in figure (2). The network is trained using the backpropagation-training algorithm [9]. The collected data from the SS if 1volt-step input is applied to the preamplifier is shown in figure (3). The input signal $U_p(k)$ is applied to the plant as well as the network and the error signal is then feedback to the network. The aim of the learning is to minimize the R.M.S error.

The learning rate was chosen by trial and error for the MRNN, typical value to be chosen is (0.01).

For the recursive least square (RLS), the initial value of estimation parameter chooses to be zero ($q(0) = 0$), and initial covariance matrix $P(0) = s_0 I$ with ($s_0 = 300$). Figure (4) shows the responses of the RLS method and the SS, which is represented by the input output data collected. Figures (5) shows the modeling error of the RLS method, and figures (6) show the covariance matrix trace of the RLS, and figures (7), (8), (9), and (10) show the parameter estimates of the RLS (a_1, a_2, b_1 and b_2).

To demonstrate the capability of this neuro-identifier, the MRNN is selected with one input, six hidden and context units, and one output unit. The learning rate is chosen by trail and error and it is notice that, large learning rates cause oscillations or even instabilities to the training process as shown in figure (11). When suitably small learning rates are adopted so that no oscillations or instabilities occur, training R.M.S errors are extremely slow to reach an

acceptable error level for good results. Increasing the number of hidden units makes the achievable R.M.S error levels smaller. However the number of hidden units cannot be too large because the permissible learning rates become even smaller and the training is even slower [10]. Also, the initial values of the weights are effective in the training process, this is due to the fact that the starting point of the learning process is determined by the initial values of the weights.

The choice of activation function is not a vital problem. Practically, in the field of using NN identification, if the system to be identified is linear, a linear activation function is used. And in the case of nonlinear system, a nonlinear activation function will be used [11]. However, many tests have been carried in order to show the effect of the type of the activation function on the identification results. For this work the sigmoid activation function was chosen for the hidden and output layer. The initial values of all trainable weights are initialized at small random values between (0.5, -0.5). Figs. (12) shows the response of MRNN model and the SS.

It is clear from Figs. (4) and (12), that the MRNN represent the system under test more accurately than the RLS.

The transfer function obtained by the RLS can be written as follows:

$$G(z) = \frac{b_1 Z^{-1} + b_2 Z^{-2}}{1 - (a_1 Z^{-1} + a_2 Z^{-2})}$$

Where $a_1 = -1.7417, a_2 = 0.7419, b_1 = 0.051, b_2 = 0.051$ are the convergence parameters.

All the software has been written using MATLAB commands and Simulink application tool, version 6.



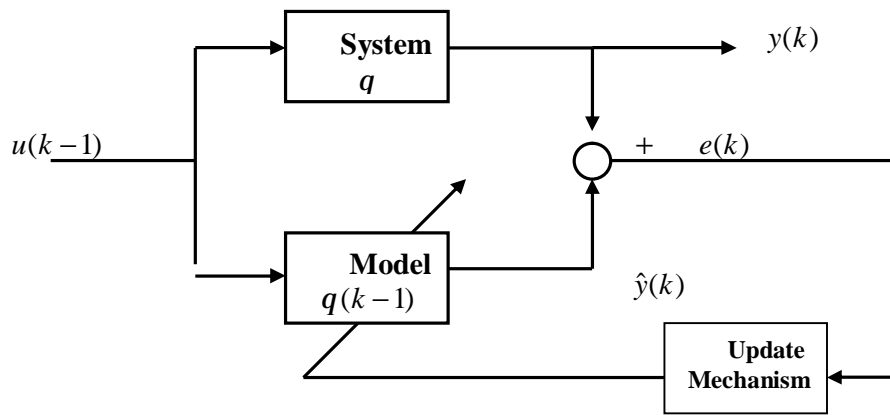

Figure (1) Visualization of Recursive Estimation

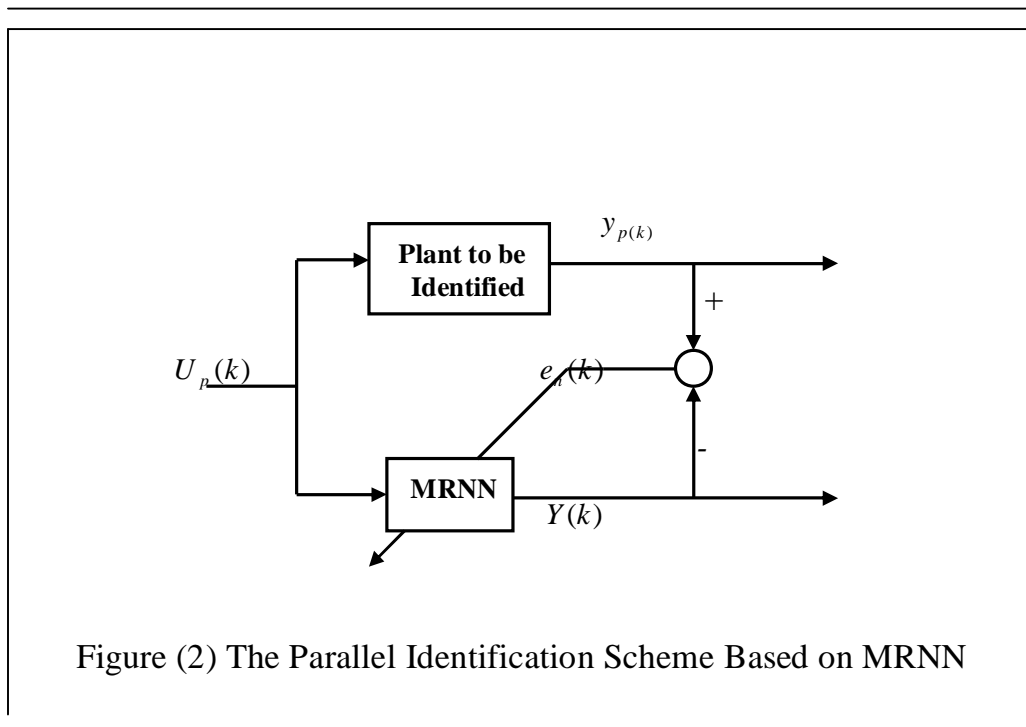

Figure (2) The Parallel Identification Scheme Based on MRNN

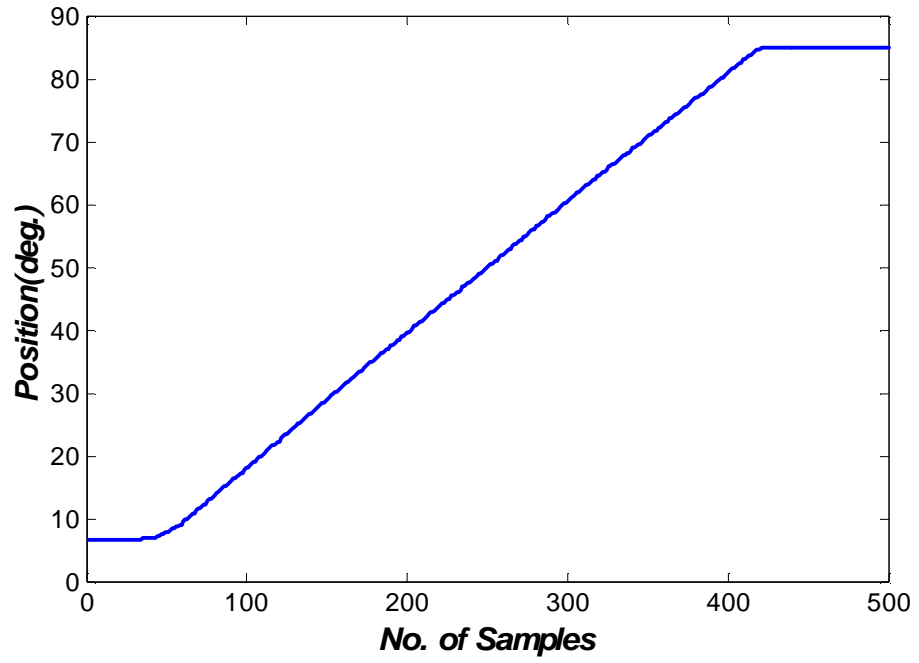

Figure (3) position of the SS exited by a 1-volt step command input

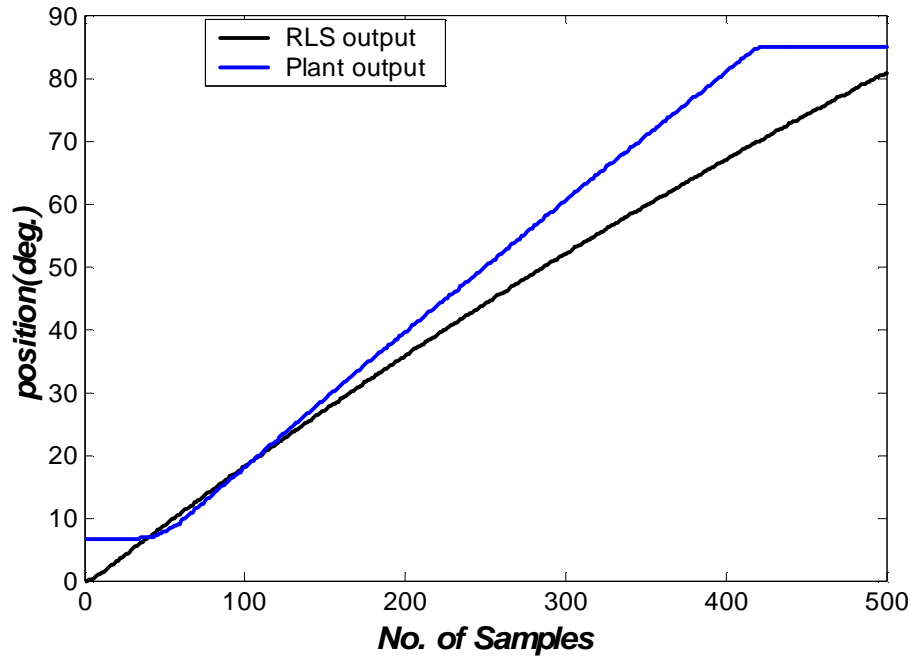

Figure (4) position of the SS exited by a 1-volt step command input and the RLS estimated position exited by the same input.

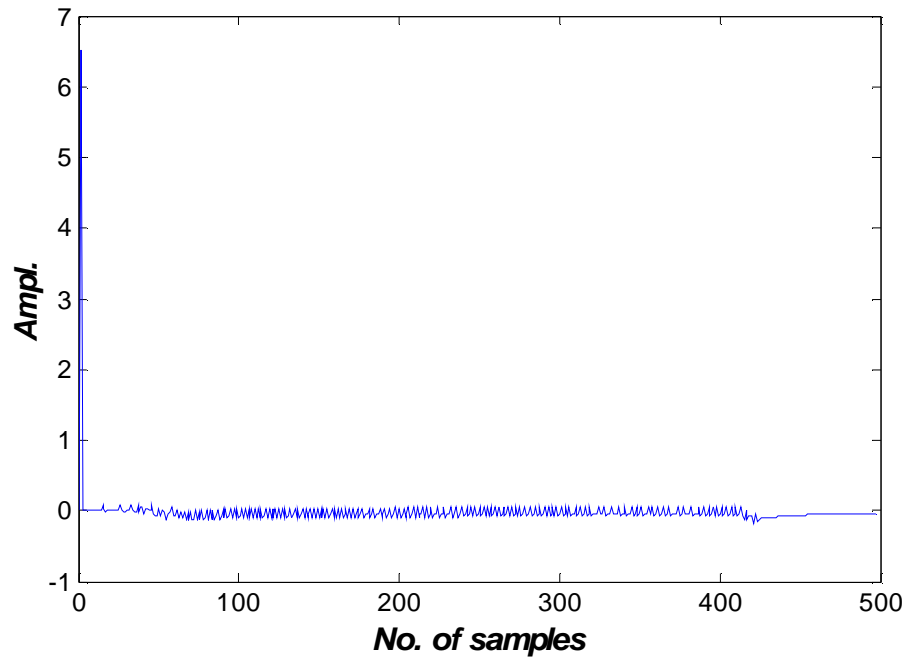
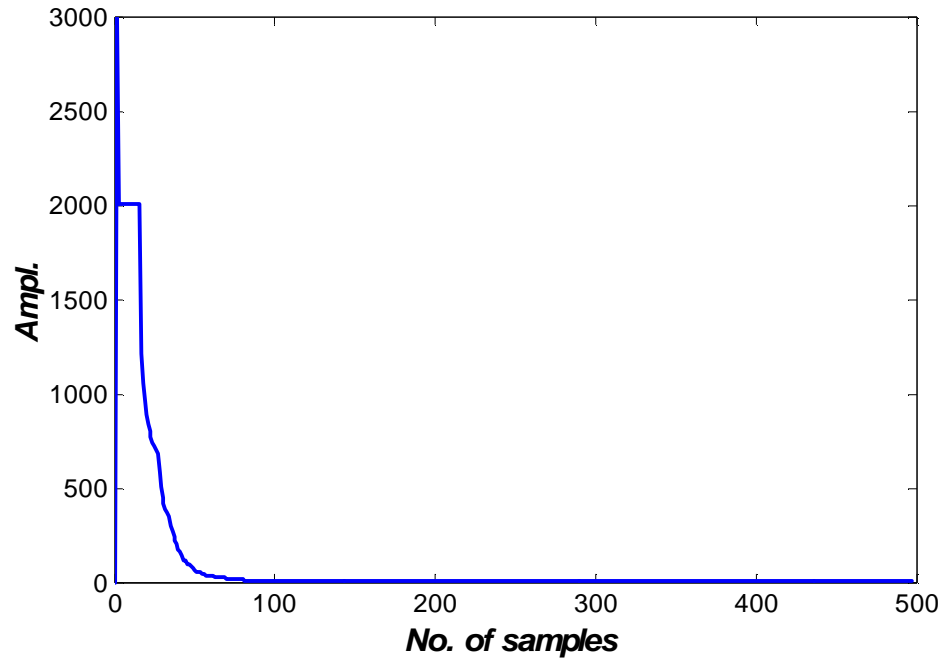

Figure (5) modeling error of the RLS



Figure(6) trace of the RLS

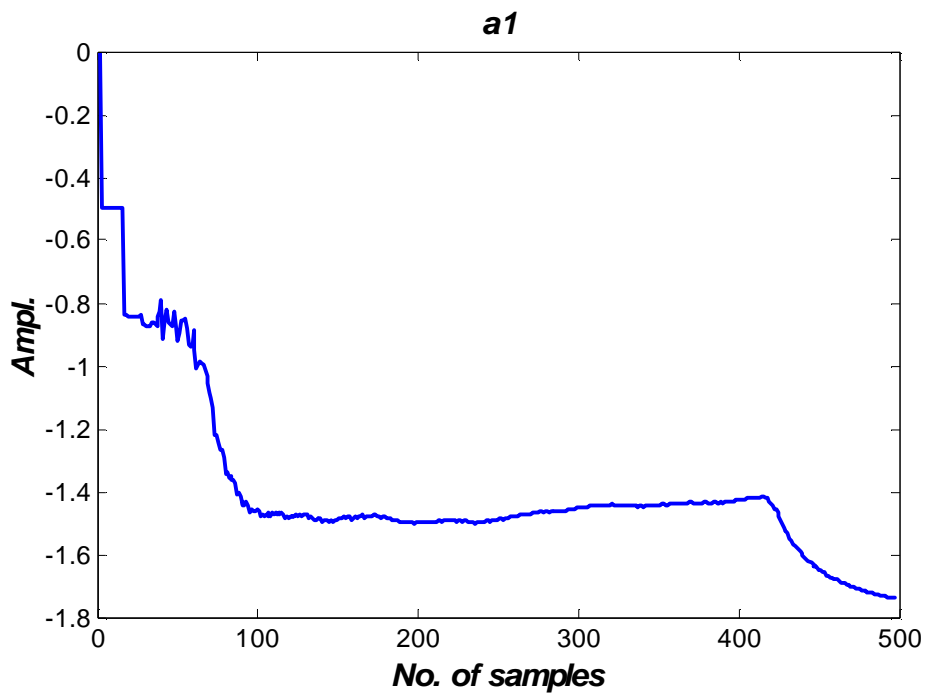

Figure (7) parameter estimate of the RLS

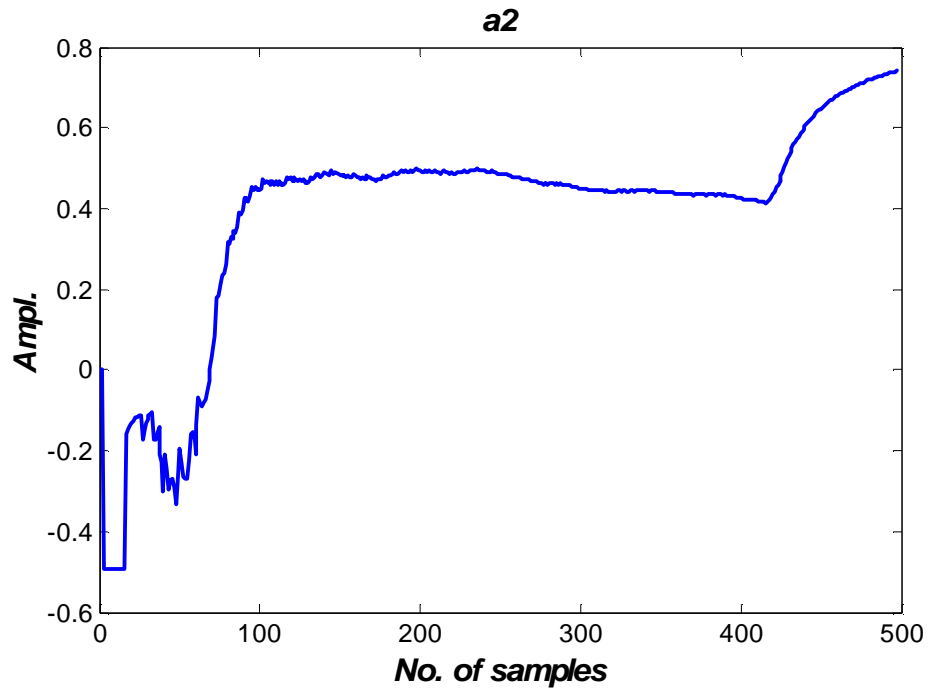

Figure (8) parameter estimate of the RLS

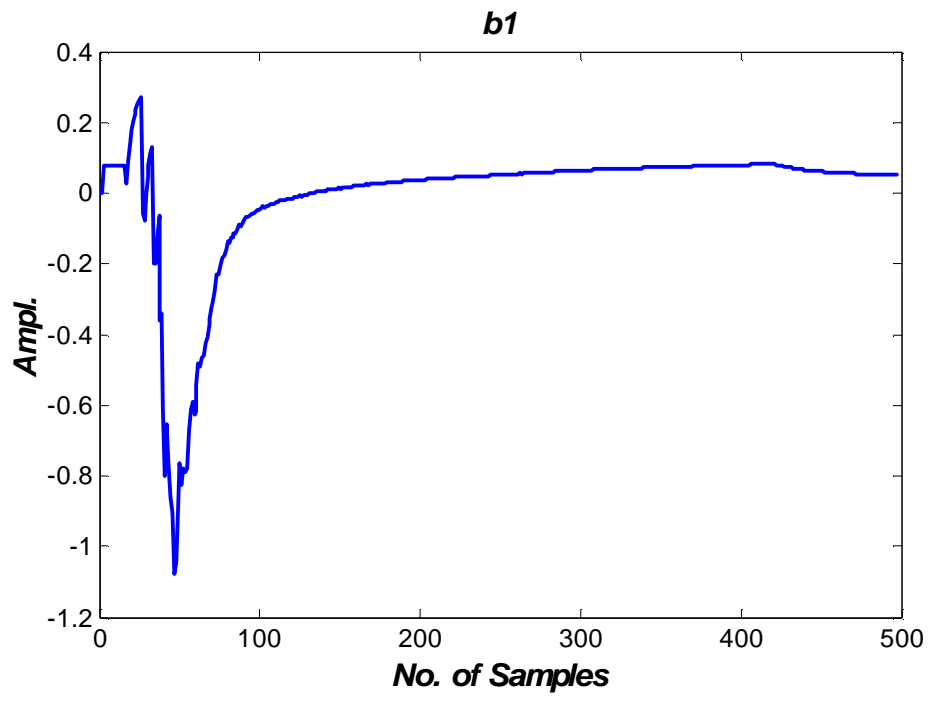

Figure (9) parameter estimate of the RLS

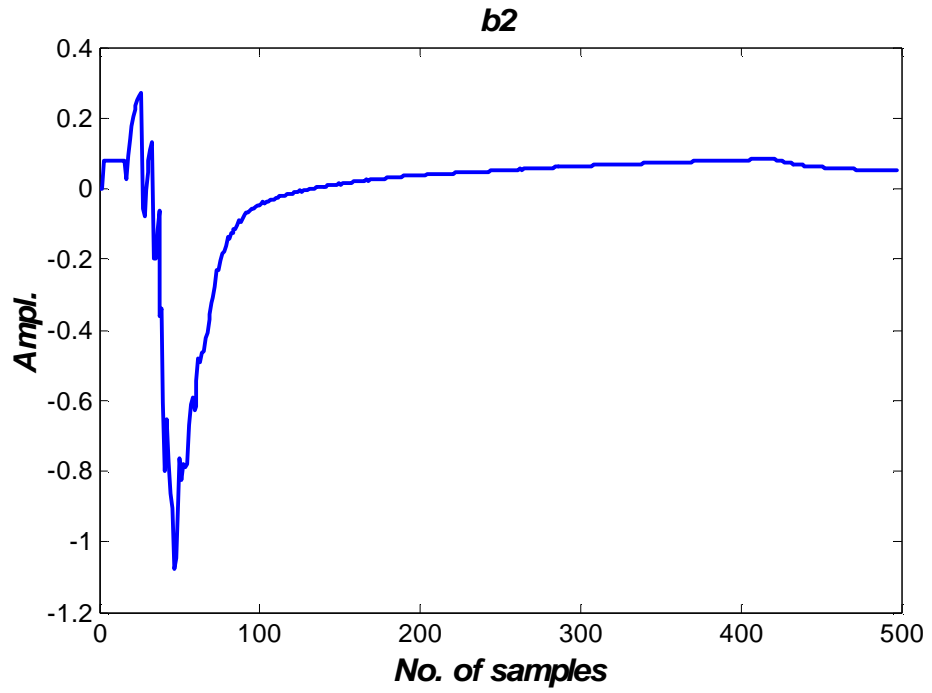

Figure (10) parameter estimate of the RLS

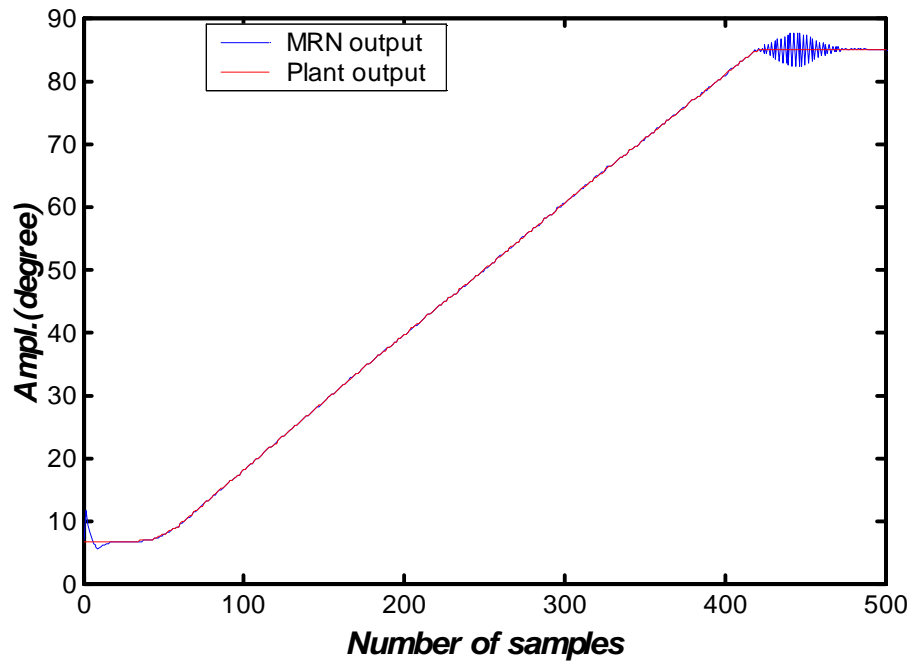

Figure (11) response of the MRNN and the SS with large learning rate

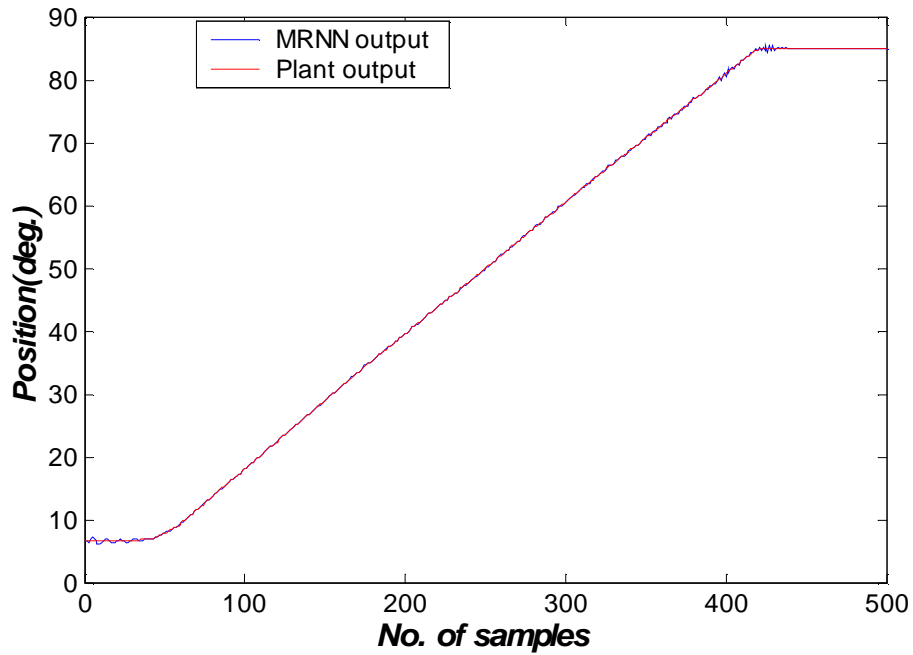

Figure (12) response of the MRNN and the SS

3. Design of PD Fuzzy Logic Controller:

The block diagram of the plant with the Proportional-Derivative Fuzzy Logic Controller is shown in figure (13).

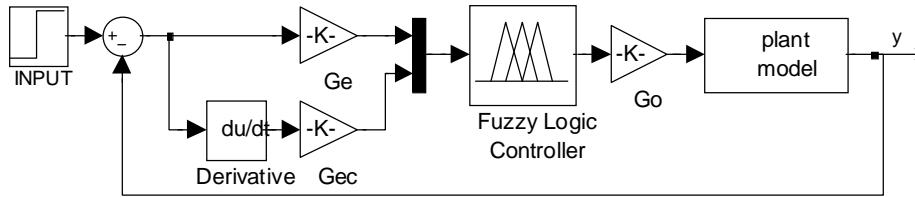

Figure (13) PD fuzzy logic controller

The inputs to the FLC is the position error $e(k)$ and position error change, $\Delta e(k)$ that is:

$$e(k) = r(k) - y(k)$$
$$\Delta e(k) = \frac{e(k) - e(k-1)}{T}$$

Where:

$r(k)$ is the reference input which represent desired angular position.

$y(k)$ is the process output which represent the actual angular position.

$T=(t_2-t_1)$ sampling period.

The output of the fuzzy controller is denoted by $U(k)$, which is the input to the plant.

In the simulation results, five triangular membership functions for each inputs and output variables are used, which are uniformly distributed across their universes of discourse for inputs and output membership functions. The fuzzy system is normalized which means the effective universes of discourse are all given by $(-1,1)$. The linguistic values of these membership functions (for inputs and output) are NB, NS, ZR, PS, and PB which stand for (negative big, negative small, zero, positive small, and positive big respectively). The complete set of rules is shown in tabulated form in table (1), the premises for the input $e(k)$ are represented by the linguistic values in the left-most column, the premises for the input $\Delta e(k)$ are represented by the linguistic values found in the top row, and the linguistic values representing the consequent for each of the rules can be found at the intersections of the row and column of the appropriate premises. Table (1) is constructed based initially on the characteristics of the system, then they are fine-tuned by repeated trials, and this table represents abstract knowledge about how to control the process given the error and its derivative as input [12].

The fuzzy operation is executed using center of gravity (COG) defuzzification method. The controller was found to have best performance when the values of the scaling factors are ($g_e = 0.29, g_{ec} = 0.09, g_o = 3$). This PD Fuzzy Logic Controller is used to control the position of the Servo System. The neuro-model obtained previously is used to represent the dynamic behavior of the actual SS. The SS response under PD FLC is shown in figure (14) and the controlled voltage of the FLC applied to the amplifier stage of the SS is traced in figure (15).

At sampling time 250, a step disturbance on the plant output of magnitude (5) was added, so the error is suddenly increases to make a high peak overshoot, as shown in figures (16) and (17). It is clear that the FLC is capable to handle this disturbance.

In the case of a conventional controller (such as PD controller) a design problem includes a proper choice of the PD controller coefficients. In the FLC design, one needs to choose many more parameters, number of rules, membership functions a scalar factors fuzzification and defuzzification procedures. These extra parameters make a FLC more robust and much more difficult for analysis [13].

Table (1)

Control Action		Change in error (Δe)				
		U	NB	NS	ZR	PS
Error (e)	NB	PB	PB	PB	PS	ZR
	NS	PB	PS	PS	ZR	NS
	ZR	PB	PS	ZR	NS	NB
	PS	PS	ZR	NS	NS	NB
	PB	ZR	NS	NB	NB	NB

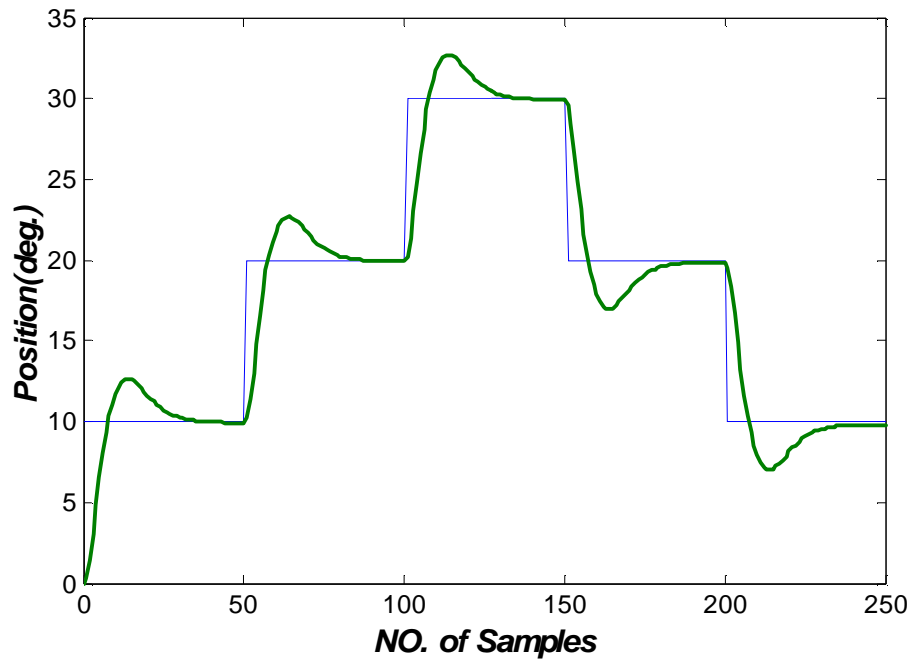

Figure (14) the output of the SS under FLC

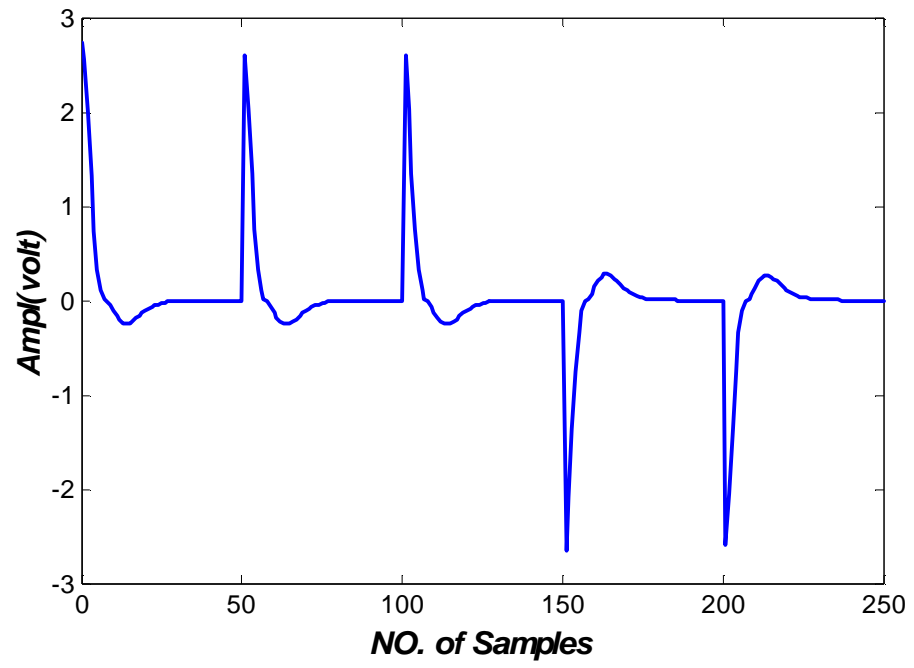

Figure (15) Control action of the FLC

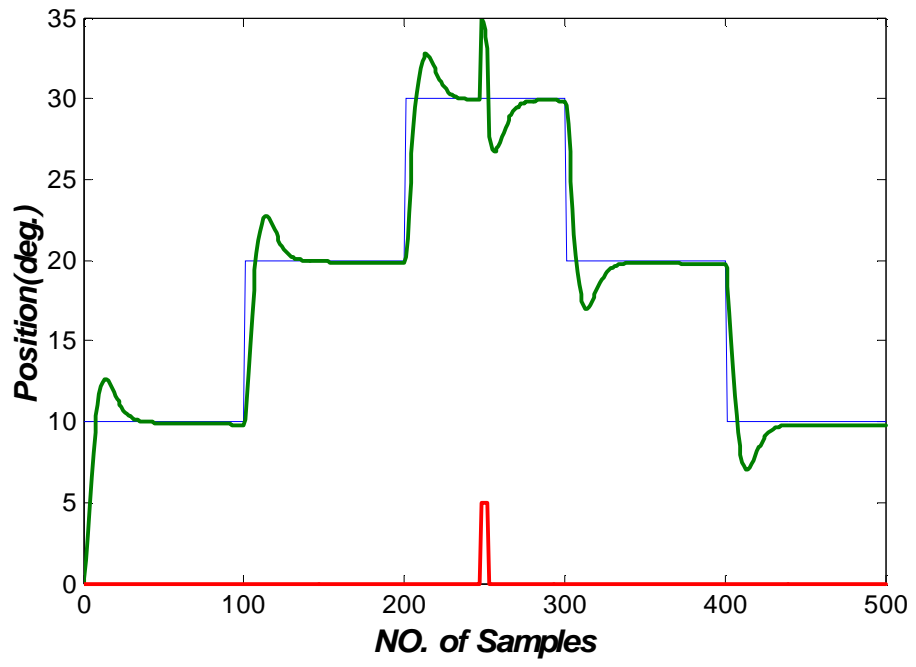

Figure (16) the output of the SS under FLC with disturbance

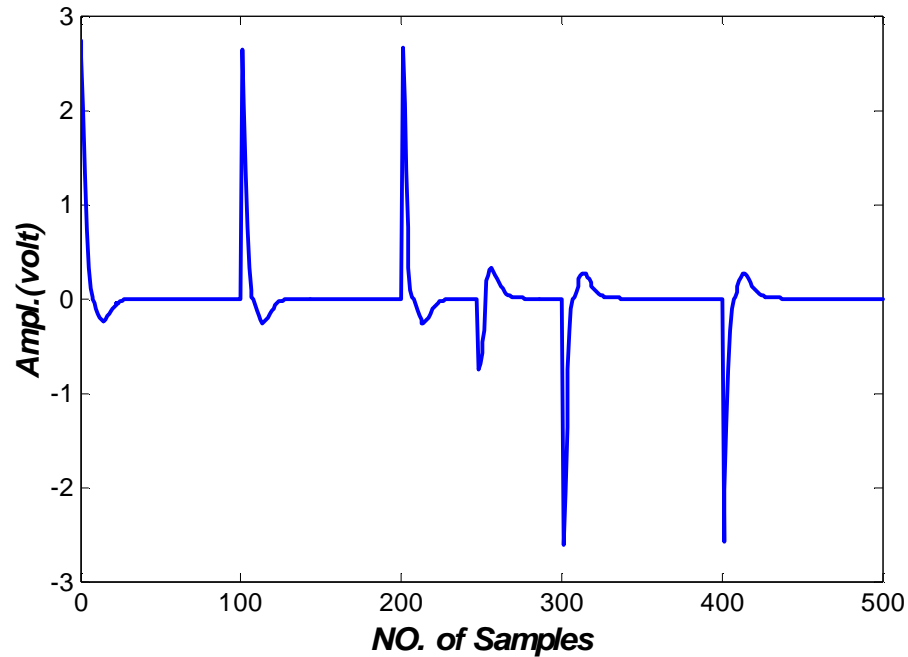

Figure (17) Control action of the FLC with disturbance

4. Conclusion

From the results presented previously, one can state the following concluding points in the field of system identification that the MRNN is more suitable for modeling or emulating dynamic plant in comparison to the conventional RLS. This ability is more clarified in the case of the case of nonlinear and noisy collected input/output data.

One can conclude the following remarks in the analysis and design of fuzzy logic controllers:

- 1. Basically, from the conventional control theory, for the position servo systems which possesses big moment of inertia reflected to the motor shaft, the necessary of designing position becomes really important point. Therefore, for the SS under consideration such control system is essential even if one try to use classical PID*

controller. It is found that for the SS, the FLC is adequate to satisfy the performance requirements.

2. To overcome the problem of system non-linearity or system parameter changes, it is recommended to use fuzzy controller that can cooperate and handle these changes.

3. The fuzzy logic controller seem to give high performance for the transient response and steady state characteristic, and shows a good robustness against external disturb

REFERENCES

- [1] M. Brown and C. Harris, "Neurofuzzy Adaptive Modeling and Control", Prentice Hall International Ltd., UK, 1994.
- [2] O. A. Hassan, "Hybrid Fuzzy Controller Design for non-linear Control Systems", M.SC. Thesis, College of Engineering at the University of Baghdad 2000.
- [3] K. S. Narendra and K. parthasarathy, "Identification and Control of Dynamical Systems Using Neural Networks", IEEE Transactions on Neural Networks, vol.1, No.1, pp. 4-27, March 1990.
- [4] J. M. Zurada, "Introduction to Artificial Neural Systems", Jaico Publishing House, 2nd edition. India, 1996.
- [5] K. M. Passino and S. Yurkovich, "Fuzzy Control", Addison-Wesley Longman, Inc., 1998.
- [6] L. Reznik, "Fuzzy Controllers", Victoria University of Technology, Melbourne, Australia Newnes, 1997.
- [7] M. M. Ali, "Neurofuzzy Controller Design" PHD, Thesis, control and systems department, UOT, 1998.
- [8] P. E. Wellstead and M. B. Zarrop "Self-Tuning Systems: Control and Signal Processing", Johan Wiley and Sons LTD., England 1991.
- [9] W. M. AL-Rawi, "Implementation of Neuro-Identifer for Dynamical Systems", M.SC. Thesis, Military College of Engineering 2001
- [10] D. T. Pham and X. Liu, "Neural Networks for Identification, Prediction and Control", Springer-Verlag, New York, 1997.

[11] G. Paulo, H. Jorge, A. Dourado and H. D. Ramos, "Application of A Recurrent Neural Network in on-line Modeling of Real Time System" CISUC Informatics Engineering Department, Coimbra-Portugal, 2000.

www.erudit.de/erudit/events/seit.99/12598-P

[12] T. Tan, S. Murakoshi, and M. Uman, "Neuro-Fuzzy Hybrid Control System of Tank Level In Petroleum Plant", IEEE TFS, vol.4, No.3, pp.245-254, may 1997, Abstract of Published Papers.

<http://www.ewh.iee.org/tc/nnc/pubc/abstracts.html>

[13] M. Golob "Decomposed Fuzzy Proportional-Integral-Derivative Controllers", Applied Soft Computing: Engineering Design and Manufacturing, Maribor, Slovenia 2001.

<http://www.au.feri.uni-mb.si/marjan/>