

Channel Equalization Using Wavelet Denoising

M. H. Miry*

Received on: 4/4/2007

Accepted on: 7/10/2007

Abstract

A problem in digital signal transmission occurs when a signal in one signal interval overlaps the signal in an adjacent interval. This problem is called intersymbol interference and limits the speed of digital transmission. Interference and noise are common in communication channels, and the recovery of transmitted signals may be a difficult task. The adaptive equalizer which is used to recover the transmitted signals and LMS algorithm which is one of the most efficient criteria for determining the values of the adaptive equalizer coefficients are very important in communication systems, but the LMS adaptive equalizer suffers response degrades and slow convergence rate under low Signal-to- Noise ratio (SNR) condition. The present work is concerned with the development and application of wavelet transform based denoising technique for improving the response and convergence rate of LMS adaptive equalizer in digital communication systems under low SNR.

Keywords: Adaptive Equalizer, LMS, Wavelet Transform, Wavelet Denoising

تعديل القناة باستخدام إزالة تشويهِه الموجية

الخلاصة

المشكلة في إرسال الإشارات الرقمية تحدث عندما فترة الإشارة تتداخل مع فترة الإشارة المجاورة. هذه المشكلة تدعى تداخل الرموز و هي تحدد من سرعة الأرسال الرقمي. التداخل و التشويه كلاهما شأنان في قنوات الاتصالات, فأستعادة الإشارة المرسله تصبح مهمة معقدة. المعادل المتكيف المستعمل لأستعادة الإشارات المرسله و خوارزمية مربع المعدل الاقل (LMS) التي تعتبر واحده من اغلب المعايير الكفوة لحساب قيم معاملات المعادل المتكيف كلاهما يعتبران جدا مهمين في أنظمة الاتصالات, لكن المعادل المتكيف LMS يعاني انخفاض في استجابته و بطء في معدل التقريب عندما تكون نسبة الإشارة الى التشويه (SNR) واطنة. هذا البحث مختص بتطوير و تطبيق محول الموجية بالاعتماد على تقنية إزالة التشويه لتحسين الاستجابة و معدل التقريب للمعادل المتكيف LMS في أنظمة الاتصالات الرقمية عندما تكون (SNR) واطنة.

* Department of Electrical and Electronic Engineering, University of Technology
Email: Mohammed_miry@yahoo.Com

1. Introduction

Adaptive signal processing is a very important part of statistical signal processing and has applications in diverse areas including communications, control, radar, sonar, and biomedical engineering. A wide variety of signal processing problems involve nonstationary signals or time-varying models, and the standard approach to resolving them involves application of adaptive filters. The number of applications where they have been successfully employed is very large, and examples of it are linear prediction, adaptive equalizer, beamforming, interference cancellation, and system identification [1,2].

The data transmission through communication system is distorted by the channel, this dispersion results in intersymbol interference. In principle, if the channel is known precisely it is virtually always possible to design an equalizer that will make the intersymbol interference (at the sampling instants) arbitrarily small. However, in practice a channel is random in the sense of being one of an ensemble of possible channels. Consequently, a fixed equalizer designed on average channel characteristics may not adequately reduce intersymbol interference. An adaptive equalizer is then needed which can be "trained", with the guidance of a suitable training signal transmitted through the channel, to adjust its parameters to optimal values. If the channel is also time-varying, an adaptive equalizer operating in a tracking mode is needed which can update its parameter values by tracking the changing channel characteristics

during the course of normal data transmission. In both cases the adaptation may be achieved by observing or estimating the error between actual and desired equalizer responses and using this error to estimate the direction in which the parameters should be changed to approach the optimal values. A simple and effective technique to determine the values of the coefficients for adaptive equalizer is least mean square (LMS) algorithm [3-5] which is developed by WIDROW. The main limitation of the LMS adaptive equalizer is the SNR of the channel controls the convergence rate of LMS adaptive equalizer and its quality. A low SNR leads to slower convergence and in item eye pattern (the eye pattern is constructed by collecting multiple traces of the signal at the output of the equalizer) we note the 'eye is close' means that information retrieval is not possible.

In this paper, the possibility of using a wavelet transform for enhancement of the performance efficient and convergence rate of LMS adaptive equalizer under weak SNR environment is explored. The wavelet transform based on pre-processing is used to reduce additive noise of data and then the data is applied to LMS adaptive equalizer. It is shown that denoising leads to fast convergence of LMS adaptive equalizer and opens the eye pattern (means that information retrieval is possible) under low SNR environment.

2. Principle of LMS Adaptive Equalizer

The linear adaptive equalizer with LMS algorithm (LMS adaptive equalizer) considered in this paper is depicted in Fig(1). The linear adaptive equalizer consists basically of a linear adaptive transversal filter (transversal filter are actually FIR discrete time filters) and the least mean square (LMS) algorithm is used to update the filter coefficients.

The LMS adaptive equalizer transforms the input signal $x(t)$ into the output signal $z(t)$. The equalizer signal is sampled at regular intervals T . As the input signal we consider a PAM base-band signal

$$x(t) = \sum_{n=-\infty}^{+\infty} a_n h(t - nT) + w(t) \quad (1)$$

where the a_n is quantized pulse amplitudes, $h(t)$ is the channel response, T is the baud interval, and $w(t)$ is the adaptive noise. Let \mathbf{c}_n be the vector of equalizer coefficients, and \mathbf{x}_n the vector of tap output signals, both at the n th sampling instant. These vectors are N -dimensional, N being the number of taps. Throughout the paper a prime (') denotes transposition. At the n th sampling instant the output signal of the equalizer reads

$$\mathbf{z}_n = \mathbf{c}_n \mathbf{x}_n \quad (2)$$

and update the tap weights \mathbf{c} in the LMS adaptive equalizer according to the equation

$$\mathbf{c}_{n+1} = \mathbf{c}_n + \Delta \mathbf{e}_n \mathbf{x}_n \quad (3)$$

where \mathbf{c}_{n+1} is the coefficient vector at time $n+1$, \mathbf{c}_n is the coefficient vector at time n , Δ is called the step size parameter and \mathbf{e}_n is the error signal at time n evolving according to

$$\mathbf{e}_n = a_n - \mathbf{z}_n \quad (4)$$

We choose as the error criterion the minimization of the expected mean-square distortion [6],

$$\mathbf{x}^2 = E[e_n^2] \quad (5)$$

where $E[.]$ denotes expectation.

The step size parameter controls the rate of the convergence of the algorithm to optimum solution [7]. A large value of Δ leads to large step size adjustments and thus to rapid convergence, while small value of Δ results in slower convergence. However if Δ is made too large the algorithm becomes unstable. To ensure stability, Δ must be chosen to be in the rang [8]

$$0 < \Delta < \frac{1}{10NP_x} \quad (6)$$

where P_x is the power in the input signal.

But in low SNR, even if Δ is selected according to equation (6), a slower convergence is obtained.

3. Wavelet for Signal Denoising

Wavelet is one of the most powerful tools in digital signal processing. It is often used in denoising method because of its energy compaction ability.

3.1 Wavelet Transform

The wavelet transform (WT) [9] is a time-scale representation technique, which describes a signal by using the correlation with translation and dilatation of a function called "mother wavelet". Wavelet shape can be selected to match the shapes of components embedded in the signal to

be analyzed. Such wavelets are excellent templates to separate those components and events from the analyzed signal waveform. The discrete wavelet transform (DWT) is a batch method, which analyses a finite-length time-domain signal into coarse approximation and detail information. Approximations represent the slowly changing features of the signal and conversely details represent the rapidly changing features of the signal.

3.2 Wavelet Denoising

The wavelet denoising algorithm involves the following steps:

1. Acquire the noisy digital signal.
2. Compute a linear forward discrete wavelet transform of the noisy signal.
3. Perform a non-linear thresholding operation on the wavelet coefficients of the noisy signal.
4. Compute the linear inverse wavelet transform of the thresholded wavelet coefficients.

This simple four-step process is known as wavelet thresholding or shrinkage. A more precise mathematical formulation of the above wavelet denoising procedure is needed.

Wavelet denoising [10-11] for signal denoising attempts to recover the discrete-time signal $f(t), t = 1, 2, \dots, M$ from the noise-corrupted observations

$$y(t) = f(t) + v(t), t = 1, 2, \dots, M \quad (7)$$

where $v(t)$ is zero-mean white

Gaussian noise of variance σ^2 . If W represents the Discrete Wavelet Transform (DWT), equation (7) in the wavelet domain becomes

$$Y_w = F_w + V_w \quad (8)$$

where $Y_w = W_y, F_w = W_f$ and $V_w = W_v$. DWT is an orthonormal transform that compacts the signal into a few large coefficients in F_w , while v is mapped onto V_w which likewise is zero-mean white Gaussian noise with variance σ^2 . The process of wavelet denoising is to threshold the coefficients Y_w to discard small values most likely due to the additive noise [12-13]. Then, these thresholded wavelet coefficients are applied to inverse discrete wavelet transform (IDWT) to obtain denoising signal.

3.3 Thresholding Operators

There are two types of thresholding operators (thresholding transform) $T(., I)$ associated with the threshold I , the hard thresholding operator $T_h(., I)$ and the soft thresholding operator $T_s(., I)$ which will be defined.

The hard thresholding operator is defined as:

$$S = T_h(Y_w, I) = \begin{cases} Y_w, & \text{if } |Y_w| \geq I, \\ 0 & \text{otherwise.} \end{cases} \quad (9)$$

The soft thresholding operator on the other hand is defined as:

$$S = T_s(Y_w, I) = \begin{cases} \text{sign}(Y_w)(|Y_w| - I) & \text{if } |Y_w| > I \\ 0 & \text{otherwise} \end{cases} \quad (10)$$

where S is the thresholded wavelet coefficients obtained after applying the thresholding operator $T(., I)$.

The transfer functions of the hard and soft thresholding schemes are illustrated in Fig (2). Note that hard thresholding is a “keep or set to zero” procedure and is more intuitively appealing. On the other hand, soft thresholding shrinks coefficients above the threshold in absolute value. While at first sight hard thresholding may seem to be natural, the continuity of soft thresholding has some advantages. Sometimes, pure noise coefficients may pass the hard thresholding and appear as annoying “blips” in the output. However, soft thresholding shrinks these false structures. Once the thresholding operator $T(., I)$ has been defined, it remains to address the problem of selecting the corresponding threshold I .

3.4 Threshold Selection

As one may observe, threshold determination is a very important question when applying the wavelet thresholding scheme. A small threshold may yield a result close to the input, but the result may be still be noisy. A large threshold on the other hand, produces a signal with a large number of zero coefficients. This leads to an overly smooth signal. Paying too much attention to smoothness generally suppresses the details and edges of the original signal and causes blurring and ringing artifacts.

The most original threshold is known as the universal threshold. Originally, Donoho and Johnstone proposed the use of the universal threshold [14]:

$$I_{univ} = \sqrt{2 \ln(M)} \times S, \tag{11}$$

where M is the length of the signal,

It has been shown that, when using the soft thresholding operator $T_s(., I)$, with $I = I_{univ}$, the following [15] with high probability is gotten, which asymptotically tends to unity as the signal size M increases, the denoised signal is at least as smooth as the original noise-free signal, where smoothness is measured by any wide range of smoothness measures.

4. Proposed Model

Having explained the LMS adaptive equalizer and wavelet denoising technique, the proposed system for adaptive equalizer by using wavelet denoising is depicted in Fig (3).

The main procedure of the system is described as follows. First, the original signal a_n is transmitted through the communications channel $h(t)$, and subject to noise $n(t)$. Next, the received signal $y(t)$ is applied to the three steps involved in the wavelet denoising process. Then, the output of the wavelet denoising technique $x(t)$ is sampled at the symbol rate or twice the symbol rate, the sampled signal x_n is applied to LMS adaptive equalizer. Finally, the output of the LMS adaptive equalizer $z(n)$ is applied to slicer (the slicer is actually a quantizer) and the output of slicer is quantized signal \hat{a}_n . The flowchart of the proposed model is shown in Fig (4).

5. Simulation and Results

In order to compare the performance of the above proposed system in a noisy environment, it is simulated using the channel

characteristics shown in Fig(5), the performance of the proposed models has been evaluated by computer simulation using Matlab 7 language. Through this channel the transmitted signal consists of values ($a_n = \pm 1$) at a SNR of 15 dB and length of the signal is $M=2000$. The equalizer comprises $N=31$ taps. Initially, set all tap weights to 0 except the center tap-weight which is set to 1. The adaptive filter is working on decision directed mode and the step parameter of the adaptation algorithm (the filter) is $\Delta=0.001$ (according to equation 6). The slicer in this simulation is actually quantizer, the rule of this slicer is that it quantizes the signal to 1 when the signal is greater than 0.5 and quantizes the signal to -1 when the signal is less than 0.5. In this simulation, we consider two cases: the first corresponds to classical system (adaptive equalizer without wavelet denoising processing); and the second corresponds to modified system (with applied proposed model). The parameters are used in second case include Daubechies wavelet (db18), soft thresholding operator, the noise variance is $\sigma^2 = 0.5181$, the universal threshold is $I_{univ} = 2.111$ (according to equation 11). In this work, the degree of success of adaptive equalization can be viewed in what is known as an "eye pattern". The results after classical system and after modified system at SNR of 15 dB are shown in Fig (6). With classical system, the eye pattern of Fig (6a) is close, not sharp and unclear. It shows a wide disparity in the positive sinc pulses, and a similar disparity in the negative pulses, thus

indicate the presence of distortion in the sinc pulses which is associated with intersymbol interference and that mean that equalizer is not efficiency. After modified system, the pattern of Fig (6b) is open, sharp and clear. The positive sinc pulses are tightly clustered. Intersymbol interference has been greatly diminished. The likelihood of mistaking a positive pulse for a negative one is reduced, and sensitivity to random channel noise is also reduced. The adaptive process with modified system has forced all positive pulses to have close to (+1) amplitudes at their strobe times (at the center of the image) and forced all negative pulses to have (-1) amplitudes at their strobe time. Fig (7) illustrates the performance of the classical system and modified system for convergence rate at a SNR of 15 dB. The convergence of the classical system is very slow because of the low SNR while the convergence of the modified system is faster than classical system, because wavelet denoising improves the SNR.

6. Conclusion

This paper has compared, through analysis and simulation, proposed system and classical system for adaptive equalizer. In the paper, a new system is proposed for adaptive equalizer by applying the received signal at receiver to wavelet denoising and then using LMS adaptive equalizer. A new algorithm has been proposed which moderately has three advantages over the classical algorithm in low SNR environment. One, it is more efficient to eliminate intersymbol interference. The second is its low

sensitivity to noise because the wavelet denoising processes improves the SNR. The third, it offers faster convergence time.

References

1. Haykin, S., Adaptive Filter Theory, third edition, Prentice-Hall, Upper Saddle River, NJ, 1996.
2. Liu, J., " Equalization in high speed communication system" IEEE circuits and system magazine, vol. 4, no 2,pp. 4-17, April 2004
3. Widrow, B., and Stearns, S.D., Adaptive Signal Processing, Prentice-Hall, New Jersey, 1985.
4. Diniz, P. S. R., Adaptive Filtering: Algorithms and Practical Implementation, Kluwer Academic Publishers, Norwell, 1999.
5. Qureshi, S. U. H., Adaptive Equalizer, Proc. IEEE, vol. 73, pp. 1349-1387, September 1985.
6. Hirsch, D., and Wolf, W. J., "A Simple Adaptive Equalizer for Efficient Data Transmission," IEEE Trans. Commun. Technol. Com-18,5 1970
7. Proakis, J. G., Digital Communication,; McGraw-Hill, New York 1995
8. Ingle, V. K., and Proakis, J. G., Digital Signal Processing Using MATLAB[®] V.4, PWS Publishing Company, 1997.
9. Uzay E. Emir¹, Ceyhan B. Akgül², Ata Akın¹, Ayşın Ertüzün², Bülent Sankur², Kerem Harmancı² " Wavelet denoising vs ICA denoising for function optical imaging", Proceedings of the 1st International IEEE EMBS Conference on Neural Engineering Capri Island, Italy . March 20-22, 2003
10. Paraschiv-Ionescu, A., Jutten, C., Aminian, K., B. Najafi, B., and Ph. Robert. Source separation in strong noisy mixtures: a study of wavelet denoising pre-processing, Proceed. Of ICASSP'2002, Orlando (USA), May, 2002
11. Oliver Rioul, and Martin Vetterli, "Wavelet and Signal Processing" , IEEE signal processing Magazine, Vol. 8, ISSN 1053-5888, pp. 14-37, October 1991
12. Donoho, D. L., "De-noising by soft thresholding," IEEE Trans. Information Theory, Vol. 41, 613-627, 1995.
13. Donoho, D. L., and Johnstone, I. M., "Ideal spatial adaption via wavelet shrinkage," Biometrika, 81, 425-455, 1994.
14. Donoho, D. L., "Nonlinear wavelet methods for recovery of signals, densities, and spectra from indirect and noisy data," in Proc. of Symposia in Applied Mathematics, vol., 00, pp. 173-205, AMS, 1993.
15. Donoho, D. L., and Johnstone, I.M., "Ideal spatial adaptation via wavelet shrinkage," Biometrika, vol. 81, pp. 425-455, 1994.

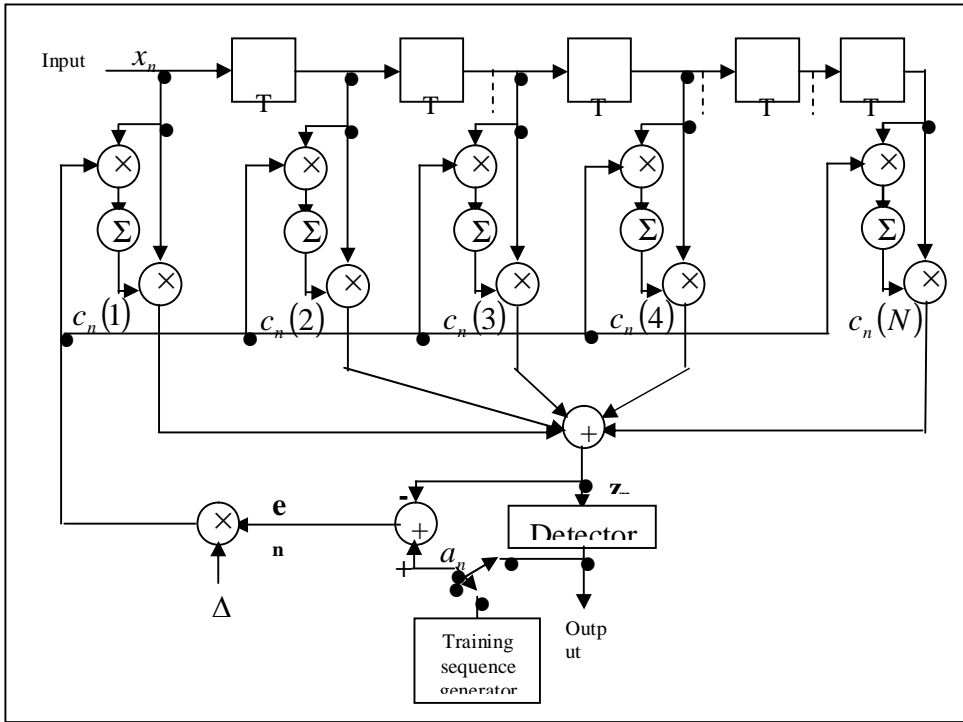

Figure 1: LMS Adaptive Equalizer

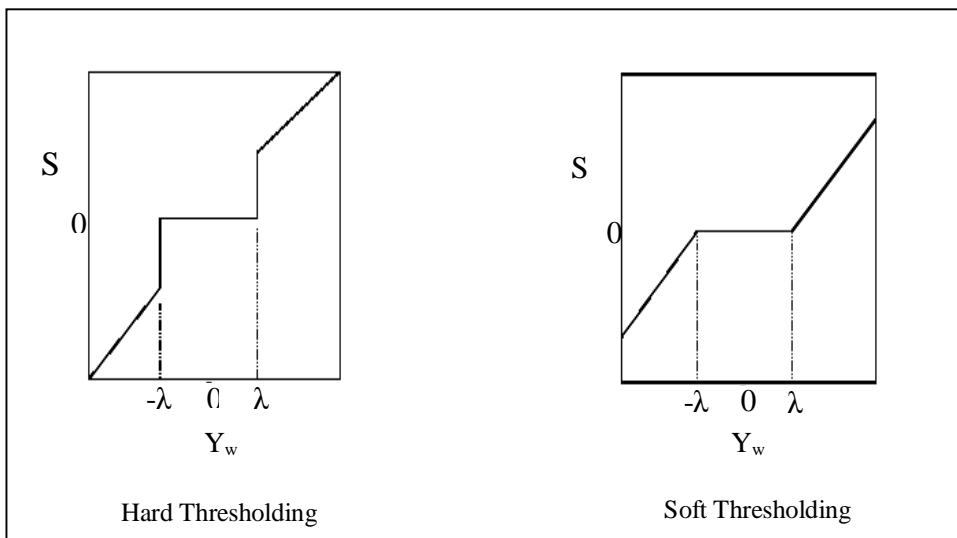

Figure 2: Hard and Soft Thresholding Operators as Applied on the Wavelet Coefficients

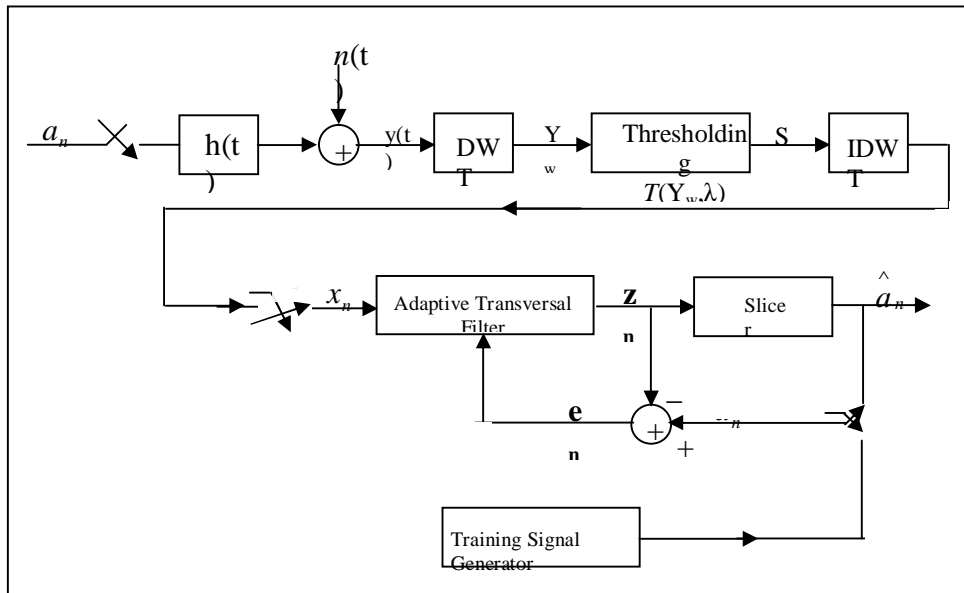

Figure 3: Block Diagram of the Proposed System

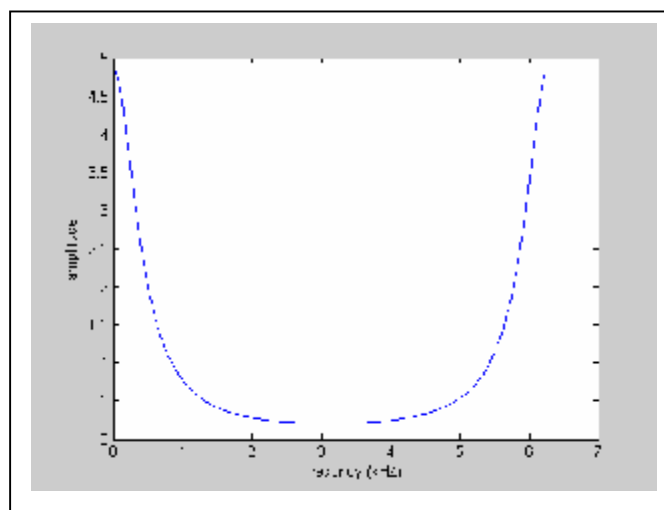
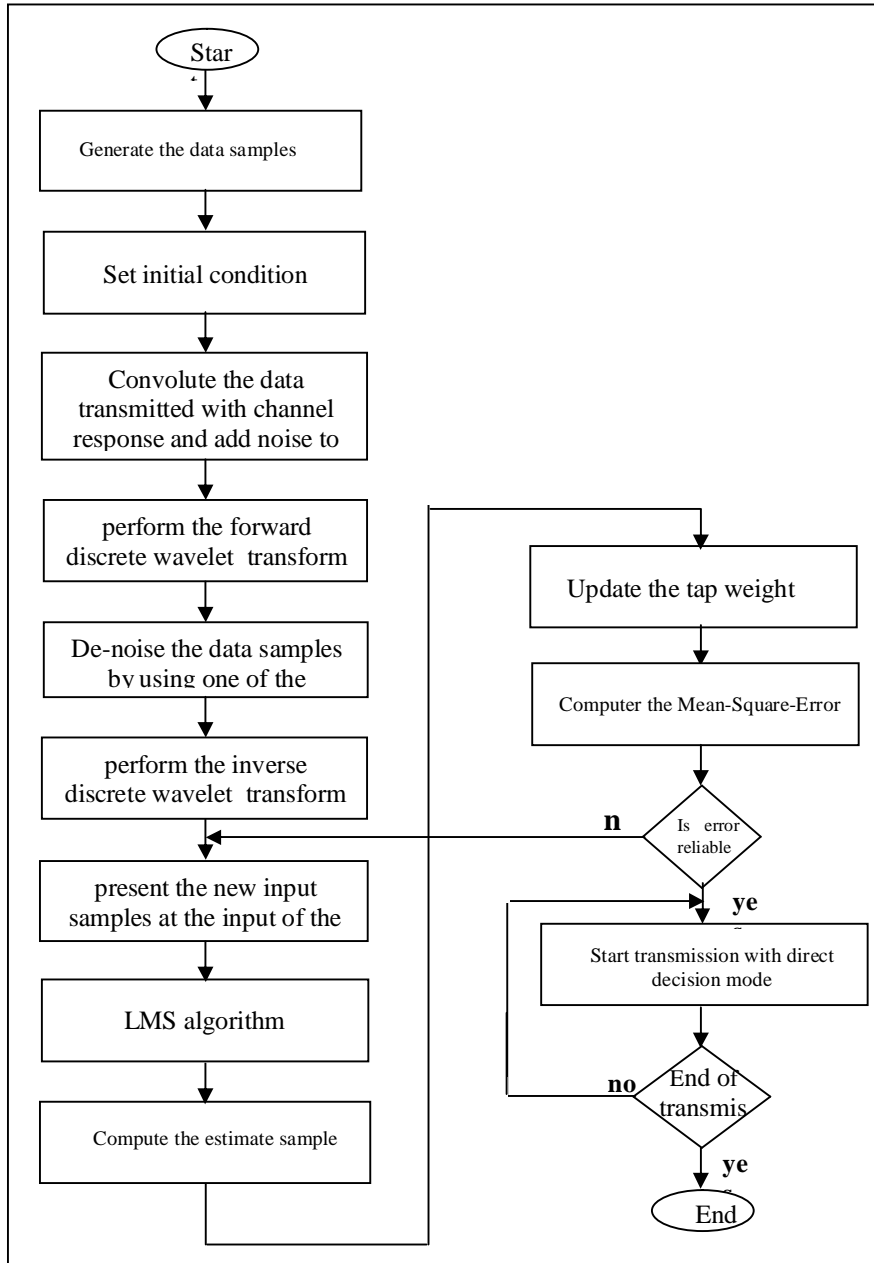

Figure 5: Channel Characteristic



Figure(4): Flowchart of the proposed model

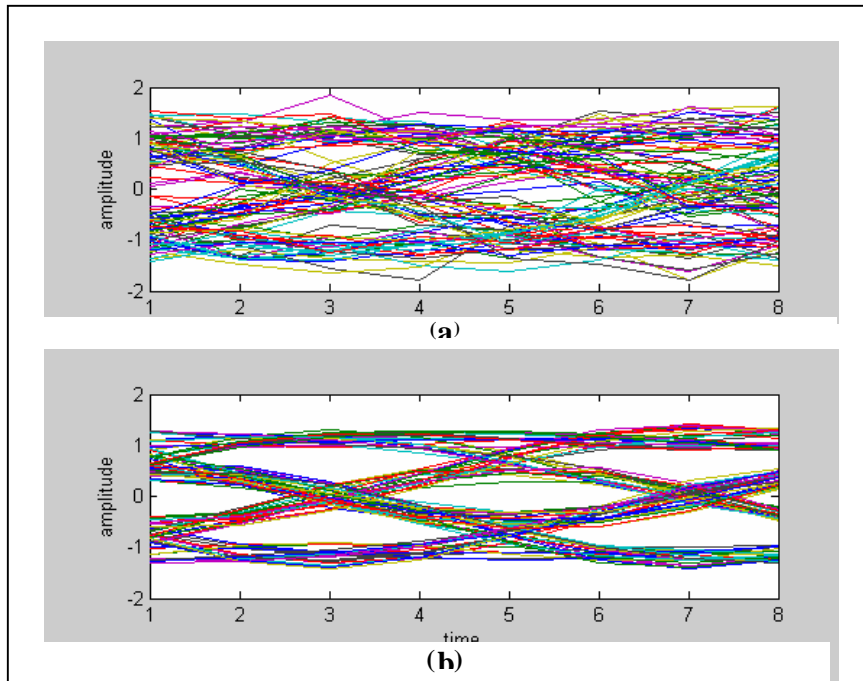

Figure 6: Eye Patterns with SNR=15 dB: (a) After Classical System (b) After Modified S System

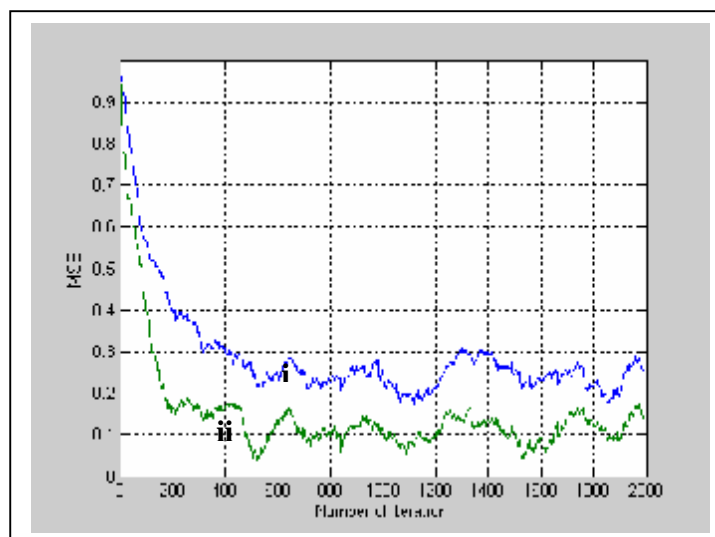

Figure 7: Comparison of Convergence Rate for the Classical System and Modified System with SNR=15 dB (i) Classical System (ii) Modified System