



Contents lists available at <http://qu.edu.iq>

Al-Qadisiyah Journal for Engineering Sciences

Journal homepage: <http://qu.edu.iq/journaleng/index.php/JQES>



Structural behavior of lightweight reinforced concrete columns subjected to eccentric loads at high temperature

Faaiza Al-Naqeeb^a and Haitham Al-Thairy^{b*}

^a MSc student at Civil Eng. Depart. / College of Eng./ University of Al-Qadisiyah, Iraq

^b Civil Eng. Depart. / College of Eng./ University of Al-Qadisiyah, Iraq

ARTICLE INFO

Article history:

Received 5 May 2021

Received in revised form 2 June 2021

Accepted 13 June 2021

Keywords:

Eccentricity,
lightweight concrete,
normal weight concrete,
temperature,
ultimate strength.

ABSTRACT

This paper presents an experimental investigation on the behavior of six reinforced concrete columns under elevated temperature. A lightweight expanded clay aggregate (LECA) was used in three reinforced concrete columns, in remaining three columns natural aggregate was used. All reinforced concrete (RC) columns have similar square cross-sectional dimensions of 150mm×150 mm, and 1250mm total length. The columns were designed according to ACI Committee 318-2014 and exposed to different elevated temperatures of 400 °C and 500 °C. After exposure to elevated temperature, the columns were axially loaded by compression force using an eccentricity ratio (e/h) equal to 0.5. The experimental results demonstrated a remarkable decrease in the ultimate carrying capacity of the columns when subjected to elevated temperature. The experimental test results have also revealed that the lightweight reinforced concrete columns have more fire resistance than the normal weight reinforced concrete columns under same elevated temperature. The ultimate load capacity of lightweight reinforced concrete (LWRC) columns decreases by about 6.5 % and 14.3 %, at elevated temperature of 400 °C and 500 °C respectively, compared with the control column at ambient temperature. However, the ultimate load capacity of normal weight reinforced concrete (NWRC) columns decreases by about 14.15 % and 28.6 %, at elevated temperature of 400 °C and 500 °C ,respectively, compared with the control column at ambient temperature. This reduction in the load resistance of the columns might be due to degradations in all properties of concrete and reinforcing steel bars when exposed to high temperatures. In addition, one of the possible reasons for the reduction in the load resistance may be due to decrease in bond strength between concrete and steel, when subjected to heat.

© 2021 University of Al-Qadisiyah. All rights reserved.

1. Introduction

A column is a vertical structural member with a height-to-least-lateral-dimension ratio greater than three is usually used to carry compressive loads D. J. Akers et al.[1] . The columns are considered as the most important members because they transfer loads to the supports and foundations and any failure in the column has a critical location may cause significant damage to the building A. Alhassnawi, M. and Alfatlawi

[2]. Hence, it is necessary to pay attention to strengthening the columns and making them fulfil their intended purpose. Concrete is widely used as a primary structural material in building construction where fire resistance is one of the key considerations in the design. The elevated temperature induced from fire could cause a deterioration of material and mechanical properties of structural members. For lightweight concrete (LWC),

* Corresponding author.

E-mail address: haithamalkalidy@yahoo.com (Haitham Al-Thairy)

<https://doi.org/10.30772/qjes.v14i2.750>

2411-7773/© 2021 University of Al-Qadisiyah. All rights reserved.



This work is licensed under a [Creative Commons Attribution 4.0 International License](https://creativecommons.org/licenses/by/4.0/).

expanded clay is a more convenient from others type of aggregate, because it does not deform at high temperatures, and during heating of concrete at high temperature, where this aggregates have lower expansion V. Jocius and G. Skripkiunas [3]. Lightweight aggregate has superior heat stability, lower thermal expansion, and lower thermal conductivity coefficient than normal-weight concrete [4, 5]. In addition, lightweight aggregate concrete (LWAC) has many benefits, including enhanced resilience, expanded fire-resistant capability, significantly minimizing dead load and element dimension F. Zulkarnain and M. Ramli [6]. Furthermore, one of the structural importance of LWC is in fire resistance as its thermal expansion is low (about half) compared with NWC Real et al. [7] in addition to the low density, and low thermal expansion coefficient [1]. Most kinds of LWC inherently possess good fire resistance compared to NWC Chandra et al. [8].

Moreover, the residual strength of LWC was found to be higher than that of NWC after exposure to fire according to ACI 213R [9]. Therefore, one possibility of using LWC is to protect steel bars when exposed to high temperature. In addition, the LWC advantage in columns is typically based on a drop in project costs, high efficiency or a mixture of both materials I. L. Concrete and A. Wet [10]. The LWC had a better performance in the raised temperature condition compared with the normal aggregates concrete. This results was obtained from many researches [10,11,12,13].

There are no adequate studies on the use of lightweight concrete in the design of concrete columns exposed to elevated temperatures. Haddad and Ashour [14] conducted an experimental study to investigate fibrous lightweight aggregate concrete small columns' thermal efficiency. Seventy-two column specimens with dimensions of 120×120 mm (width and height) and 400 mm length with different lateral confinements of steel were sampled and casted with and without fiber reinforcement of hooked steel. The prepared specimens were test at age of 28 days of curing and subjected to higher heating degree ranged from 300 °C to 700 °C. From the results it has been noted a remarkable decrease in rigidity and the compressive of the load capacity, in addition to an increment within their strain at peak stress when exposure temperatures up to 400 C. Thermal cracking was related to exposure heat, with the use of steel fibers or steel confinement minimizing the frequency of the cracking. Column specimen failure modes ranged from brittle to semi-ductile, with longitudinal steel buckling observed in those heated to 700 C.

Construction professionals are particularly concerned with the behavior of building structures in certain conditions, thus constructing buildings and structures that minimize the risks to people and property to the extent possible of the business and standing in the construction business[15],[16]. Also, the columns which were subjected to eccentric loading collapsed as the concrete was compressed in the compression face of the column after clear displacements and cracks fomented in the stress face Othman et al. [17].

A significant number of studies were conducted on the effect of fire on reinforced concrete columns and other studies focus mainly on the fire influences on the eccentrically loaded RC columns. For instance, an experimental study was conducted by Jau and Huang [18] on twenty-two reinforced concrete corner columns with 2700 mm length and cross-sectional dimensions of (300×450mm) under high temperature .The parameters considered in the tests were the concrete cover thickness, concrete compressive strength, reinforcement ratio, eccentricity ratio, and

fire duration. It was observed that the eccentricity proportion, the compressive strength of concrete, the steel reinforcement ratio, the cover thickness of concrete, and the fire period are the variables influencing the occurrence of cracks in the essential series. The presence and features of surface fractures, nevertheless, do not explicitly contribute to the reduction in strength.

Lie and Woolerton [19] presented an experimental study to examine the effect of different parameters such as the shape of cross section, thickness of concrete cover, reinforcement, aggregate type, load, and load eccentricity on the fire resistance of RC columns. Forty-one full-size RC columns were cast and tested under standard fire conditions. The test results have revealed that using carbonaceous aggregate increased the fire resistance of RC columns. Also, heavy reinforcement columns were noticed to give higher fire resistance and the end conditions influenced the slenderness ratio of the column, which in turn decreased the fire resistance with increasing slenderness ratio.

The effect of fire flame burn on the performance and load-carrying capability of reinforcement concrete columns was investigated by Kadhum [20]. One hundred and twenty columns were classified to two series with target compressive strength of 30 and 40 MPa, and series labeled A and B, respectively. The first set samples were concentrically loaded, while the second and third set samples were loaded with eccentricities of 30 and 80 mm. Column specimens have been designed to sustain a full capacity load cell (150 tons) with a lifetime of 2 months after being burnt at temperature ranges of 400, 600, and 750 °C with a fire flame over an exposure time of 1.5 hours. Test results have shown that the rise in fire temperature has a major influence on the mid-height lateral deflection of column samples for series A and B series.

This research presents and discusses an experimental study of the behavior of LWRC columns and NWRC columns exposed to elevated temperatures under eccentric loading. Finally, this study will come up with useful and essential conclusions that may be used for more practical and safer design of eccentrically loaded RC columns exposed to elevated temperature.

2. Experimental program

2.1. RC column specimens

Six RC columns were considered in this study and designed according to ACI 318-14 [21]. Based on the tests of compressive strength, the normal weight RC columns also cast using NWC and LWC with equivalent compressive strength equals to 27 MPa, and 17 MPa, respectively .

2.1.1. Material characteristics

1. Concrete mixture:

Karasta ordinary Portland cement (Type I) manufactured in Iraq was used for concrete mixes throughout the work. This cement complied with the Iraqi specification (IQS, No.5:1984) [22].

Fine aggregates were used from well-graded natural sand with a fineness modulus of 2.49 and SO₃ equals to 0.23 % conforming to the Iraqi specification (IQS, No.45:1984) [23], Zone 2. Also, The expanded clay aggregate (LECA) with dry density of 434 kg/m³, maximum size of 10 mm, specific gravity of 0.293, fineness modulus 3.19, and absorption

of 35.68% , and fineness modulus of 3.07 was used as a full replacement of the coarse aggregate (see Fig. 1).

The sieve analysis test of LECA shown in Table 1 indicates that the lightweight aggregate used is complying with the requirements of the ASTM C-330 [24], and coarse aggregate with a maximum size of 14 mm was used according to Iraqi specifications (IQS No. 45/1984) [23] to obtain NWC. The LWC mixture with mix proportions of 1:1.744:0.5 (cement: sand: aggregate) and with water cement ratio (w/c) of 0.3 was designed based on ACI code (ACI 211.2-1998) [25] and utilized to cast the RC columns. Also, the NWC mixture with mix proportions of 1.0:1.6:2.6 (cement: sand: aggregate) and with water cement ratio (w/c) of 0.41 was designed based on ACI code (ACI 211.1-1991) [26] and utilized to cast the RC columns. Three concrete cubes with dimensions of 150mm× 150mm×150 mm and three concrete cylinders with 200mm height ×100mm diameter for each mixture, have been cast, cured, and tested to determine the tensile and compressive strengths of the concrete at ambient temperature based on ASTM C 2012 specifications [27]. The findings demonstrated that the concrete's average tensile and compressive strengths are 1.49 MPa and 17 MPa, respectively for NWC, and 1.98 MPa and 27 MPa respectively for LWC. In addition, the dry density of LWC and NWC was 1840.6 Kg/m³ and 2361.5 Kg/m³, respectively.



Figure 1. Light weight expanded clay aggregate (LECA) used in current study.

Table 1: Grading of light weight expanded clay aggregate.

Sieve size (mm)	Cumulative% by weight passing	Sieve size (mm)	Conformed to I.Q.S
12.5	100	100	OK
9.5	87	80-100	OK
4.75	8	5-40	OK
2.36	1	0-20	OK

2. Steel bars:

Four different sizes of deformed steel bars with diameters of 16mm, 12mm, 10mm, and 8 mm with the strength grade of G60 were utilized as longitudinal and transverse reinforcement. Uniaxial tensile tests were carried out to determine the yield stress, ultimate strength, and modulus of steel bars' elasticity, as summarized in Table 2.

Table 2. The uniaxial tensile tests result of the steel bars used in the present study

Diameter (mm)	Yield stress Fy (MPa)	Modulus of elasticity (MPa)	$\epsilon_y = F_y / E_C$	Ultimate strength Fu (MPa)
8	318	200000	0.00159	447
10	461	200000	0.002305	545
12	530	200000	0.00265	628
16	557	200000	0.002786	666.50

2.1.2 Geometrical characteristics and reinforcement details.

The geometrical and reinforcement details of the LWRC and NWRC columns specimens used in the present study are illustrated in Table 3 and Fig. 2 respectively. All columns were designed to resist the same axial compressive load which is 600 KN with eccentricity ratio (e/h) of 0.5 in order to compare the reduction in the strength of LWRC and NWRC columns after the exposed to the elevated temperature 400°C, and 500°C respectively except one column being tested without exposure to heating which is considered as the control specimen . Each column has the same square cross section with dimension of 150×150 mm and 1250 mm length. The upper and lower parts ends of the columns were designed as corbels according to ACI 318-14 [21] specifications with dimensions of 240mm width, 150mm depth, to support the bearing plate used to achieve the required eccentricity and to prevent the local crushing and bearing of the concrete due to concentration of the stress at the upper and lower ends of the column. Dimensions of the column were chosen to fit the dimensions of the electrical furnace manufactured in this study along with the dimensions of universal testing machine. In addition, for LWRC columns a minimum steel area (AS ≥ 1%) or 4Ø16mm and 2 Ø12 was used for the main longitudinal reinforcement, while for NWRC a minimum steel area (AS ≥ 1%) or 4Ø12 mm. 9 ties were used as a transvers reinforcement using Ø 8mm@131 mm c/c for each LWRC and NWRC columns, whereas, 9 ties were used as a transvers reinforcement using Ø 8mm@131 mm c/c. The corbels were designed with 2Ø16 as main reinforcement and Ø10mm at 80 c/c spacing as transverse reinforcement.

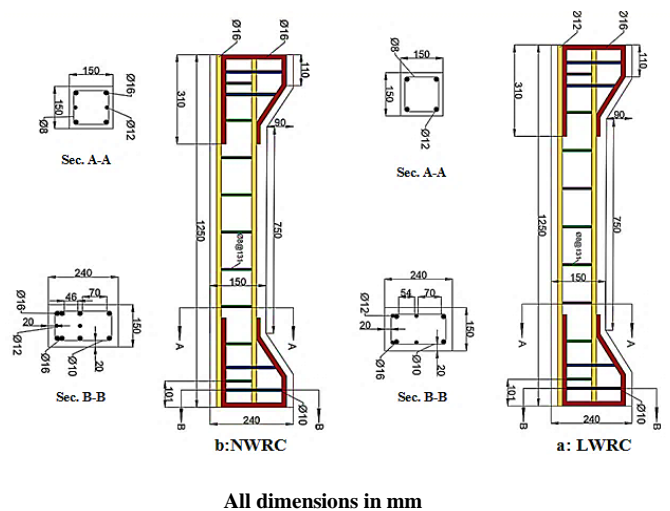

Figure 2. Dimensions and reinforcement details of RC column specimens

Table 3. Details and designation of RC column specimens.

Main reinforcement	Symbol	Stirrups	Target Temperature °C (Concrete)
4Ø16 and 2Ø12	0.5N20	Ø8 @131mm c/c	20
4Ø16 and 2Ø12	0.5N400	Ø8 @131mm c/c	400
4Ø16 and 2Ø12	0.5N500	Ø8 @131mm c/c	500
4Ø12	0.5N20	Ø8 @131mm c/c	20
4Ø12	0.5N400	Ø8 @131mm c/c	400
4Ø12	0.5N500	Ø8 @131mm c/c	500

3. Thermal and structural tests

3.1. Thermal tests

Thermal tests were conducted on the concrete cubes, concrete cylinders, two NWRC columns, and two LWRC columns, after 28 days of curing by using the electric furnace after being air-dried for 10 days. The column specimens were tested thermally in the electric furnace by exposing them to different elevated temperatures (400°C, and 500°C). The concrete cubes and cylinders were thermally heated using an approximately identical heating rate exposed to the corresponding RC columns.

The electrical furnace was used to impose high temperatures to the RC column samples before the axial compressive load was applied. The dimensions of the electrical furnace are 1300mm length, 330mm depth and 290mm height with the highest applicable temperature of 900°C.

The details of the electrical furnace equipment are shown in **Fig. 3**.

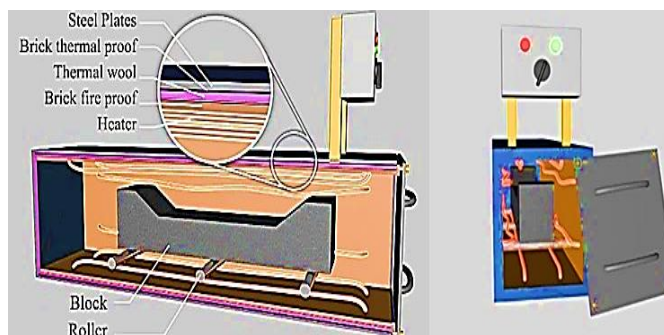
**Figure 3. Close-up details of the electric furnace.**

For each RC column specimen, a single Type-K thermocouple with a maximum temperature capacity of 600°C was connected at mid-height of main reinforcement steel bars to measure the steel temperatures inside the concrete. **Fig. 5.a** shows thermocouple used for steel bar reinforced. Also, an external thermocouple shown in **Fig. 4.b** was also attached to the concrete surface with a maximum temperature capacity of 1200°C to measure and monitor the surface temperature of the concrete. The two Type-K thermocouples were connected to a digital monitor to record the temperature of the concrete and the reinforcement steel bars during the thermal tests. The locations of the steel bars thermocouples are shown in **Fig. 4.c**.



a- Thermocouple used for steel. b- Thermocouple used for concrete.



c- Installing thermocouples to the steel bar

Figure 4. Types and positions of thermocouples.

3.2. Mechanical tests

The RC column specimens were tested using a hydraulic universal test machine with a maximum capacity of 2000 kN and minimum loading rate of 3 kN/min. A mechanical method was used in the recording and monitoring the load increment to the column. The heated RC column specimens along with the control specimens were subjected to one axial static point load up to failure using the mechanical test machine.

Two bearing plates were utilized at the bottom and top ends of the column to distribute the axial load over the loaded area and to achieve the required eccentricity. The bearing steel plate of columns is very important when testing the RC columns under eccentric loads to prevent concrete crushing and stress concentration at the column ends. The bearing steel plate is 20 mm in thickness to prevent the failure or deformation of the plate with a dimension of 150×180 mm (width ×length). The required eccentricity was achieved by using the two bearing steel plates over the corbel at the locations length such that the resultant of the applied pressure on the plate is located at the intended value of the eccentricity from the center of the column section, as demonstrated in **Fig. 5.a**. On the other hand, the boundary conditions of the column was arranged to represent the simply support condition by using a steel rods at top and bottom end with diameter of 10 mm which allow the ends to rotate freely about the perpendicular axis and prevent the end moving in vertical and horizontal directions. The load was applied in small increments and the measurements were recorded until failure occurs.

Cracks initiation and propagation were observed and marked on the surfaces of the RC columns specimens. In addition, two dial gauges of 0.01 mm accuracy were used to measure the horizontal and axial displacement: one of dial gauges was installed at the mid-height of the column to measure the horizontal displacement while other one was

placed at the lower support of the column to measure axial displacement corresponding to each load increment as shown in Fig. 5.b. The test was continued until a decrease in the loading capacity with a sudden increase in displacement was shown in the RC columns. Since the test is mechanical, load and displacement measurements were recorded manually at each load increment.

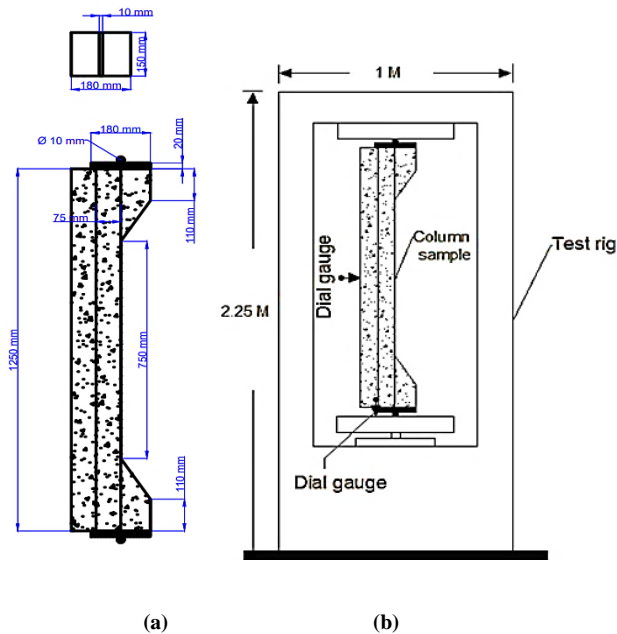

Figure 5. a) Eccentricity loading Setup, b) Installing measurements devices of column specimen

4. Tests results

4.1. Temperature–time histories

Two RC columns of each type of columns are exposed to two elevated temperatures which are 400 °C and 500°C. The cracks on the surface of the columns after being cooled with air were marked in red colour as shown in the Fig. 6. The temperature time history inside the furnace, at concrete surface and at the steel bars were measured for all heated specimens using the type-K thermocouples and shown in Fig. 7. It can be noted from this figures that the furnace heating rate were almost similar for all RC columns which is recognized by an abrupt increase in the temperatures up to 180-200 °C throughout the first ten minutes of heating time, then the rate of heating was significantly decreased to about 4°C/min up to 350°C/min. Finally, the heating rate decreased more to reach about 1-1.5°C/min and remained constant up to the end of test. All heated RC columns were cooled down naturally to air temperature. It can be noted that at elevated temperature of 400 °C, the difference in temperature between concrete and bar surfaces (ΔT (C-S)) was 57 °C in the NWRC column while in LWRC column, ΔT (C-S)) was 82 °C. Further, at elevated temperature of 500 °C, the ΔT (C-S) was 41°C in the NWRC column while in LWRC column was 132. These results confirm that LWCR columns are more fire endurance than NWRC columns. On the other hand, ΔT (C-S) is shown in Fig. 8.

The concrete samples suffer from moisture losses caused by the evaporation of water within the concrete after subjected to extreme temperatures. This approach contributes to a rise in internal tension and hence the emergence of cracks. Significant micro-cracks on samples occurred throughout the experiments due to expose to elevated temperatures are 400, and 500 °C, and one forms of concrete degradation at high temperatures may show local wear (cracks) in the material itself. Some fine cracks also occur due to the difference in thermal expansion between concrete and steel.

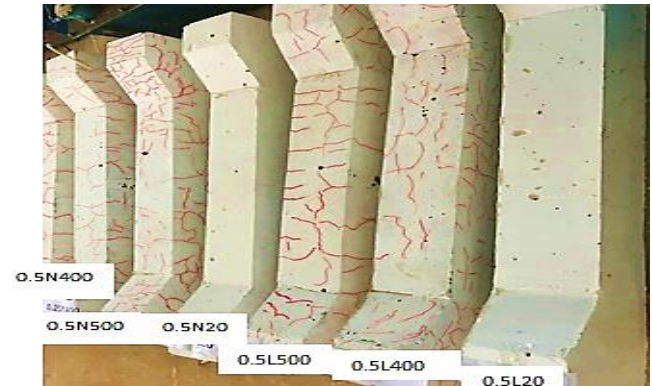
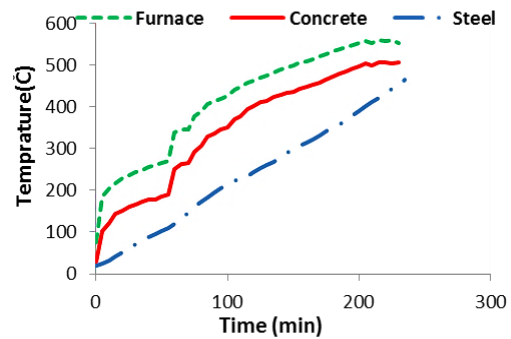
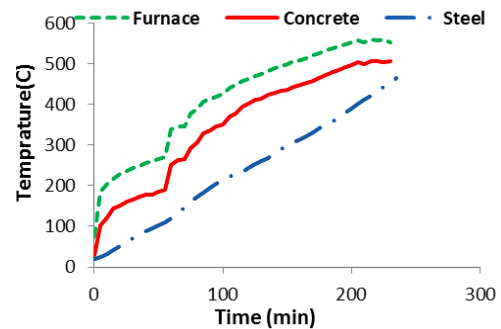

Figure 6. The thermal crack pattern for heated columns



a) Temperature 400 °C (LWRC) column



b) Temperature 500 °C (LWRC) column

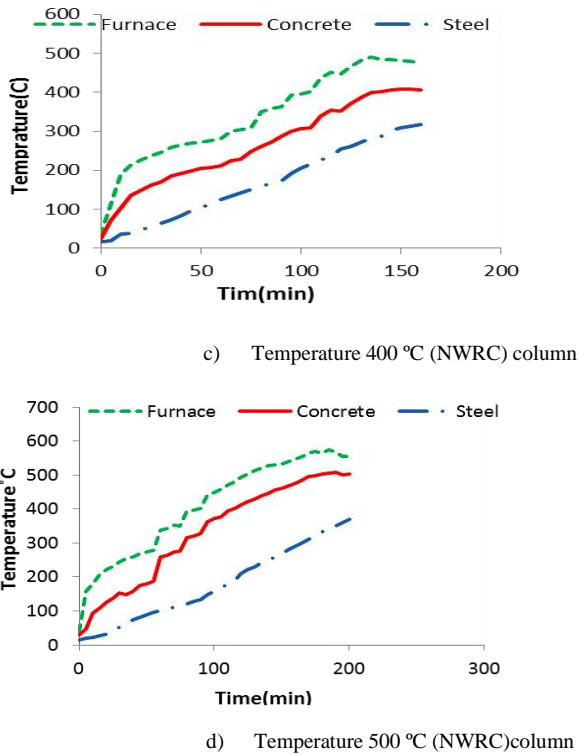

Figure 7. Time-temperature histories of LWRC columns and NWRC columns under different elevated temperature

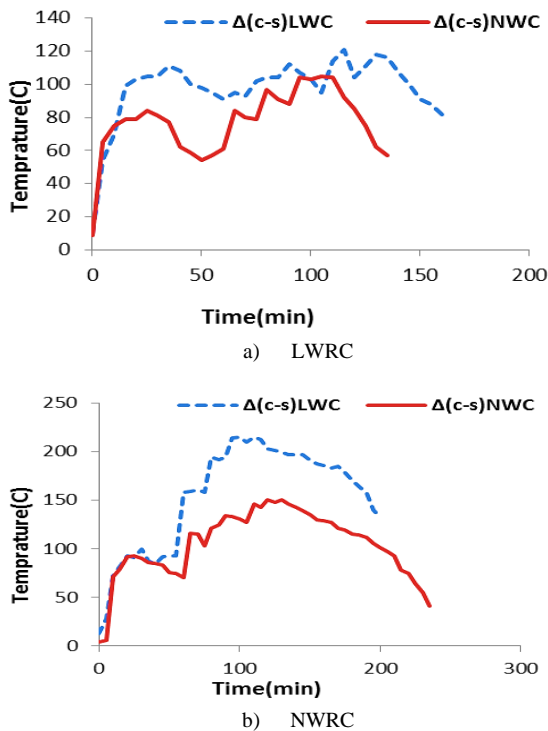

Figure 8. The difference between the temperature of concrete surface and steel bars surface with time for a) LWRC, b) NWRC columns under different elevated temperatures.

4.2. Failure modes and load-displacement relationships

The present study consisted of three LWC columns and three NWC columns that were exposed to an eccentricity loading (e/h), which is equal to 0.5, and the first for each group of columns was kept without exposure to temperature as a control specimen, and the other two columns were exposed to high temperatures (400, and 500 °C). Exposure of specimens to heat caused moisture loss because of the water evaporation inside the concrete as mentioned previously. This process was considered the main reason for increases in the internal pressures and cracks appear which in turn led to concrete weakening and deterioration. The columns that were heated to 400 and 500 °C experienced a significant increase in the number and width of cracks when loaded compared to the unheated column. The development of cracks with increased load for all specimens was also recorded until failure in columns took place due to crushing in their compression region.

In the case of LWRC columns, by applying load on the column, cracks appeared on the tension side of the column at loads of 20 kN, 20 kN, and 10 kN for columns 0.5L20, 0.5L400, and 0.5L500, respectively. Moreover, columns exposed to heat are more deformed compared with unheated column due to reduction in compressive strength and tensile strength of concrete. Furthermore, flexural compression was the predominant failure mode for all columns at which columns failed by buckling of the columns toward the compression side and crushing of concrete cover as shown in Fig. 9. The decreasing in ultimate load capacity for the columns equal to 6.5% and 13.24% at temperature of 400°C and 500 °C, respectively compared with control column 0.5L20.

Also, in the case of NWRC columns, the first cracks of the columns 0.5N20, 0.5N400, and 0.5N500 appeared at loads of 20 kN, 20 kN, and 10 kN, respectively as mentioned in Table 4. The crack pattern and failure mode of the RC columns are shown in Fig. 10. The fracture of the concrete cover in the columns occurred in different regions of the compression side. For the column 0.5N20 the crushing of concrete cover occurred at mid-height of the column, while in the column 0.5N400 the crushing occurred at the upper part of the mid-height of the column. Lastly, the fracture of the concrete cover in the column 0.5N500 was at the lower end of the mid-height of the column. Due to the eccentric loading, the investigation revealed that the general failure mode in all test specimens was the buckling of the columns, the crushing of the concrete cover on the compression side, the appearance of cracks on the tension side, and its development towards the compression side. In addition to that, the data showed that the ultimate load capacity of the columns 0.5N400 and 0.5N500 were decreased by about 14.28 % and 28.57%, respectively, compared to the control unheated column 0.5N20 as shown in Fig. 11. The decrease in the loading resistance of the columns could be due to degradations in concrete’s strength and reinforcing steel bars when they are exposed to high temperatures. Also, from Fig. 11a,b, it is shown that the lateral displacement of all columns increases with an increase in the temperature. The reason behind that can be related to the heating, which causes a reduction in column stiffness due to the reduction in the concrete elastic modulus and the reduction in the effective section because of the thermal and cracking expansions of concrete exposed to high temperature.

The influence of using LWC on the behavior and fail modes of RC column down different high temperature was investigated in this study. It should be mentioned that both NWRC and LWRC columns were designed to have same ultimate load capacity (600 kN) at ambient temperature. From the test results it has been noted that at elevated temperature the

ultimate load capacity for NWRC column specimens was less than that of LWRC column specimens with the same conditions. The ultimate load capacity of 0.5L400 column was 254.46 kN, while 0.5N400 column failed at 218.11 kN with a percent of reduction about 14.28 %. Similarly, results have shown that 0.5L500 column specimen failed at 181.76 kN while 0.5N500 column specimens failed at 136.27 kN with a reduction of about 23.07%.

Fig. 12 shows the effect of temperature on the failure load of LWRC and NWRC columns subjected to eccentric loads with eccentricity ratio ($e/h=0.5$). In addition, Fig. 12 illustrates that the reduction at the ultimate load capacity for LWRC heated specimen under 0.5 eccentricity ratios compared to the unheated column is less than the reduction of the ultimate load for the column specimens in NWRC columns because LWC has high resistance to the elevated temperature [28,13,29]. As a result, it can be concluded the efficiency of LWC is much higher when used in high temperature in comparison with NWC. Table 4 lists the results of all column samples.

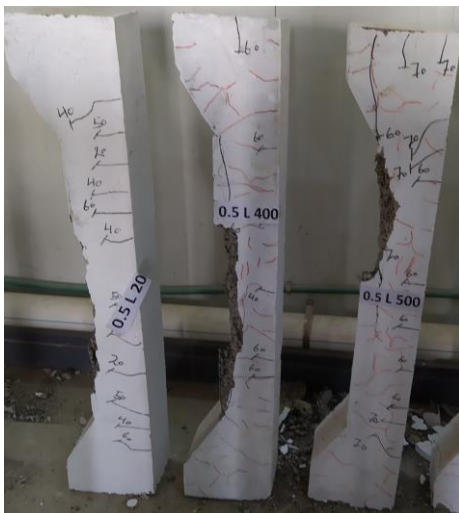

Figure 9. column specimen failure for 0.5L20, 0.5L400, 0.5L500

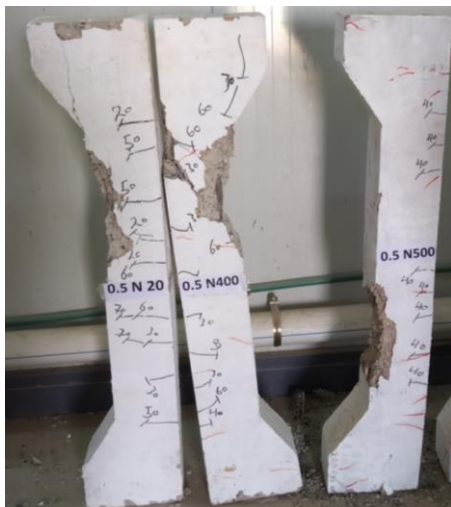
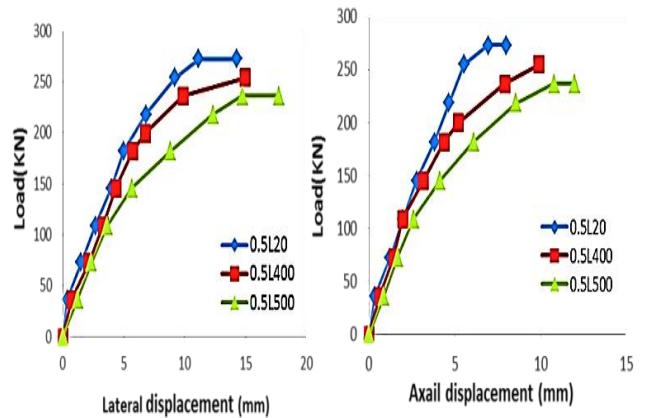
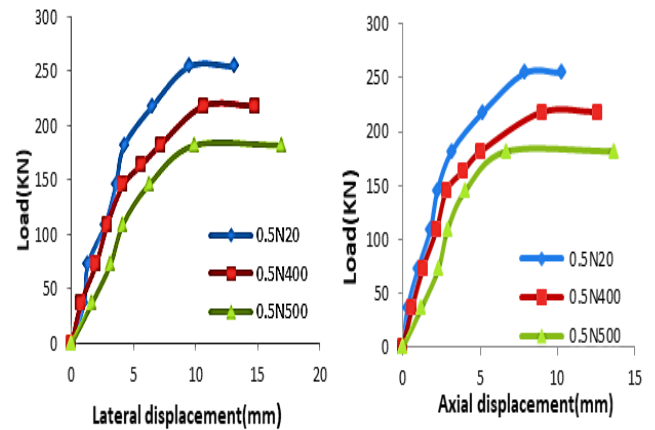

Figure 10. Column specimen failure for 0.5N20, 0.5N400, and 0.5N500



a) LWRC columns



b) NWRC columns

Figure 11. Load-lateral and axial deflection of heated and control LWRC and NWRC columns under eccentric loading ($e/h=0.5$).

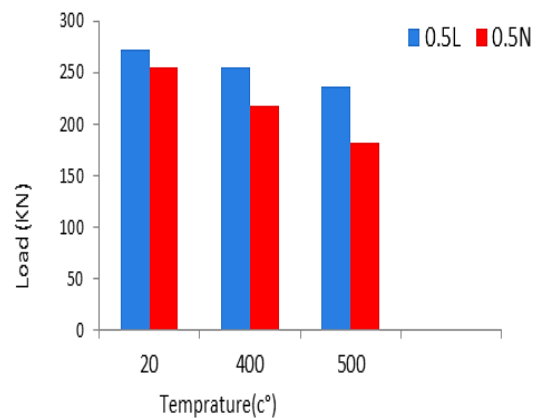

Figure 12. Effect of elevated temperature on ultimate load capacity of LWRC columns, and NWRC columns

Table 4. Experimental result for all column specimens.

Column symbol	Maximum Load carrying capacity (kN)	Percentage decreasing in load carrying capacity (%)	Ultimate axial deflection (mm)	Ultimate lateral (mid-height) deflection (mm)	P initial cracks (kN)
0.5L20	272.36	0	7.98	14.3	20
0.5L400	254.46	6.5	10.98	14.98	20
0.5L500	236.29	13.24	11.36	17.73	10
0.5N20	254.469	0	10.3	13.12	20
0.5N400	218.116	14.286	12.6	14.76	20
0.5N500	181.763	28.571	13.69	16.88	10

5. Conclusions

This paper presented an experimental study to investigate the behavior and failure modes of LWRC columns exposed to elevated temperature under an eccentric load and compared with behavior and failure modes of NWRC columns. Six samples of RC columns were tested under an eccentric load with an eccentricity ratio equal to 0.5 after heating two of each type of these with an electric oven and the other columns were kept at the ambient temperature as controls.

The behavior of the columns was recorded and evaluated in terms of temperature history and time, load-displacement relationships and failure modes have been recorded and evaluated in the study. The following conclusions can be drawn from the present study:

1. The experimental test results referred to decreasing in the ultimate load capacity with high temperatures where the residual ultimate strength of LWRC columns is equal to 93.5% and 86.76% for 0.5L400 and 0.5L500, respectively compared to the control column 0.5L20 due to the decrease of the modulus of elasticity of steel and concrete with temperature increase. Also, the residual ultimate strength of NWRC columns is equal to 85.71% and 71.43% for 0.5L400 and 0.5L500, respectively compared to the control column 0.5N20. From these results it has been noted that the columns with LWC is more efficient compared with columns with NWC.
2. It is noticed that the lateral mid height deflection and axial displacement were increased with the increase of the degree of heating when compared to the control un-heated specimen that due to reduction in stiffness of these columns that produced from heating with high temperatures.
3. Crushing in concrete and flexural buckling have been the predominant failure mode for NWRC columns under high and ambient temperatures. Also the spalling in concrete cover at compression side and flexural compression has been the general failure of LWRC columns.

REFERENCES

[1] D. J. Akers *et al.*, "Guide for structural lightweight-aggregate concrete," *ACI 213R-03. Am. Concr. Inst. (ACI), Michigan*, 2003.

[2] A. Alhassnawi, M. and Alfatlawi, "EXPERIMENTAL INVESTIGATION ON THE INFLUENCE OF ELEVATED TEMPERATURE ON(REINFORCED CONCRETE COLUMNS STRENGTHENED WITH CARBON FIBER REINFORCED POLYMER PRODUCTS.," *Int. J. Civ. Eng. Technol.*, vol. 9(10),

2018.

[3] V. Jocius and G. Skripkiunas, "The Mechanism of Disintegration of Cement Concrete at High Temperatures," *Rigas Teh. Univ. Zinat. Raksti*, vol. 18, p. 4, 2016.

[4] I. B. Topçu, "Semi lightweight concretes produced by volcanic slags," *Cem. Concr. Res.*, vol. 27, no. 1, pp. 15–21, 1997.

[5] T. D. Lin, R. I. Zwiars, R. G. Burg, T. T. Lie, and R. J. McGrath, "Fire resistance of reinforced concrete columns," 1992.

[6] F. Zulkarnain and M. Ramli, "Durability performance of lightweight aggregate concrete for housing construction," *Proc. from ICBEDC*, vol. 8, pp. 541–551, 2008.

[7] S. Real, J. A. Bogas, M. da G. Gomes, and B. Ferrer, "Thermal conductivity of structural lightweight aggregate concrete," *Mag. Concr. Res.*, vol. 68, no. 15, pp. 798–808, 2016.

[8] S. Chandra and L. Berntsson, "Lightweight Aggregate Concrete: Science, Technology and Applications (Building Materials Science Series)," *William Andrew Inc., New York*, pp. 35–63, 2002.

[9] A. C. I. C. 213, "Guide for structural lightweight-aggregate concrete," 2003.

[10] I. L. Concrete and A. Wet, "Uilding Locks," no. January, pp. 22–26, 2013.

[11] F. Koksals, O. Gencil, W. Brostow, and H. E. H. Lobland, "Effect of high temperature on mechanical and physical properties of lightweight cement based refractory including expanded vermiculite," *Mater. Res. Innov.*, vol. 16, no. 1, pp. 7–13, 2012.

[12] K. He, R. Guo, Q. Ma, F. Yan, Z. Lin, and Y.-L. Sun, "Experimental research on high temperature resistance of modified lightweight concrete after exposure to elevated temperatures," *Adv. Mater. Sci. Eng.*, vol. 2016, 2016.

[13] N. H. Albu-Hassan and H. Al-Thairy, "Experimental and numerical investigation on the behavior of hybrid concrete beams reinforced with GFRP bars after exposure to elevated temperature," in *Structures*, 2020, vol. 28, pp. 537–551.

[14] R. H. Haddad and D. M. Ashour, "Thermal resistance of steel fibrous lightweight aggregate concrete short columns," *J. Compos. Mater.*, vol. 47, no. 16, pp. 2013–2025, 2013, doi: 10.1177/0021998312453605.

[15] V. Kodur and R. McGrath, "Fire endurance of high strength concrete columns," *Fire Technol.*, vol. 39, no. 1, pp. 73–87, 2003.

[16] S. R. Al-Owaisy and M. A. Shallal, "Strength and elasticity of steel fiber reinforced concrete at high temperatures," *J. Eng. Sustain. Dev.*, vol. 11, no. 2, pp. 125–133, 2007.

[17] Z. S. Othman and A. H. Mohammad, "Behaviour of eccentric concrete columns reinforced with carbon fibre-reinforced polymer bars," *Adv. Civ. Eng.*, vol. 2019, 2019.

[18] W.-C. Jau and K.-L. Huang, "The Behavior of Reinforced Concrete Corner Columns Under High Temperature." .

[19] T. T. Lie and J. L. Woollerton, *Fire resistance of reinforced concrete columns: test results*. National Research Council Canada, Institute for Research in Construction, 1988.

[20] M. M. Kadhum, "Effect of Burning on Load Carrying Capacity of Reinforced Concrete Columns," *J. Babylon Univ. Sci.*, vol. 21, no. 4, pp. 1194–1212, 2013.

[21] A. Committee, "Building Code Requirements for Structure," 2014.

[22] I. specification No, "Portland Cement. Central Agency for Standardization and Quality Control," 1984.

[23] I. S. S. No, "Natural Aggregate Resources used in Concrete and Construction," 1984.

[24] ASTM, "Astm C330," *Stand. Specif. Light. Aggregates Struct. Concr.*, vol. 04, pp. 3–6, 2000, doi: 10.1520/C0330.

[25] J. R. Prestera *et al.*, "Standard Practice for Selecting Proportions for Structural Lightweight Concrete (ACI 211.2-98)," 1998.

[26] D. E. Dixon *et al.*, "Standard Practice for Selecting Proportions for Normal, Heavyweight, and Mass Concrete (ACI 211.1-91)," 1991.

[27] ASTM, "Standard test method for compressive strength of cylindrical concrete specimens," *Chú bién*, 2012.

-
- [28] H. M. Al-Baghdadi, "Effect of High Temperature on Some Properties of Light Weight Concrete," *Al-Qadisiyah J. Eng. Sci.*, vol. 7, no. 2, pp. 176–188, 2014.
- [29] K. AKÇAÖZÖĞLU and S. AKÇAÖZÖĞLU, "The effect of elevated temperature on the lightweight concrete produced by expanded clay aggregate and calcium aluminate cement," *Bilge Int. J. Sci. Technol. Res.*, vol. 1, no. 2, pp. 59–70, 2017.