

**K.A. Sukkar**

Chemical Engineering  
Department, University of  
Technology, Baghdad.  
[khalid\\_ajmee@yahoo.com](mailto:khalid_ajmee@yahoo.com)

**S.M. Kadhim**

Laser and Optoelectronics  
Engineering Department,  
University of Technology,  
Baghdad.

**A.S. Falih**

Laser and Optoelectronics  
Engineering Department,  
University of Technology,  
Baghdad.

## Manufacturing of Bi-functional Nano-sensor of Nobel Metal for Hydrocarbon Gas Detection in Petroleum Sector Using Pulse Laser Deposition Technique

**Abstract**-In the present investigation bi-functional nano-gas-sensor was manufactured from two types of metals: ZnO metal oxide and Pt noble metal. The nano-gas-sensors were designed for monitoring and control the environmental pollution in petroleum sector. The preparation technique was carried out by design and construction of a pulse laser deposition unit (PLD) with Nd: YAG laser ( $\lambda=532\text{nm}$ , laser fluence 2 J/cm<sup>2</sup>, repetition rate 6 Hz and the pulse duration 7ns). The target was pure ZnO and Pt:ZnO that containing 4%wt Pt. The hexachloroplatinic acid (H<sub>2</sub>PtCl<sub>6</sub>) was used as Pt source. The PLD films were deposited at three different temperatures 200, 250, and 300°C. Many characterization tests are used to study the influence of temperature on surface morphology of prepared films: Scanning Electron Microscope (SEM), Atomic Force Microscope (AFM), x-ray Diffraction (XRD) and (UV) visible. The results pointed to a direct relationship between the deposition temperature and the grain sizes of the nanoparticles formed on the substrate. On the other hand, the results of RMS roughness of AFM showed an increased value with increasing of deposition temperature. The best value of RMS roughness was 10.3nm for thin films deposited at 250°C. The x-ray results shows formation of nanostructure on the substrate at deposition temperature of 250°C, in which represent high surface area of gas sensor and especially with Pt. In addition, the UV-VIS transmittance measurements have shown that the films are highly transparent in the Visb-NIR wavelength region, with an average transmittance of about 90%. These results pointed to that the manufactured bi-metals nano-gas-sensor (Pt:ZnO) at 250°C is more suitable for LPG hydrocarbons detection application in petroleum positions.

**Keywords** Hydrocarbons LPG detection; PLD, Nano-gas sensor; bi-metals Pt:ZnO.

How to cite this article: K.A. Sukkar, S.M. Kadhim and A.S. Falih, "Manufacturing of Bi-functional Nano-sensor of Nobel Metal for Hydrocarbon Gas Detection in Petroleum Sector Using Pulse Laser Deposition Technique," *Engineering and Technology Journal*, Vol. 35, Part A, No. 8, pp. 864-871, 2017.

### 1. Introduction

In manufacturing of gas sensors technology, the metal oxide are the most used type in the detection processes of explosive, toxic, and flammable gases in petroleum and gas industry. Nanostructure materials have received much important due to their unique specification of high surface area and adsorption properties [1-3]. In the engineering application nanosize zinc oxide, ZnO regards one of the important nanomaterial applied in detection of pollutant gases. ZnO characterized by its high sensitivity, low cost, flexibility to form nanostructures, and thermal stability. It has been always due to Pulsed Laser Deposition (PLD) technique was successfully applied for enhancing qualified zno thin films. PLD plays a great roll in reducing the chemical contamination due to the use of laser light and controlling of the composition of deposited structure. Moreover, it is a manifold and powerful tool for growth of nanoparticles

with coveted size and composition by only manipulating the deposition conditions [4-6].

In petroleum industry, there are many locations that including may poisoning and flammable hydrocarbons pollutants such as (H<sub>2</sub>S, NO<sub>2</sub>, CO, CO<sub>2</sub>, and Hydrocarbons). Liquefied petroleum gases LPG (a mixture of propane and butane gas) represent the flammable hydrocarbons that present in gas stations or in petroleum refining zones [7,8]. In designing and manufacturing of gas, sensors the temperature is regarded an important factor for sensing process. Therefore, the gas sensor must possess appropriate degree of crystallinity is required [1,9,10,11]. On the other hand, the present of another metal in the film structure that prepared by PLD may be work on supporting the electrical and optical properties of prepared thin films and then the sensing process. Many others pointed to that the gas sensor performance is strongly dependent on the

chemical composition and physical specification of the gas sensor [12-16].

## 2. Experimental work

### I. material

In the present work, many chemicals were used: Zinc oxide (ZnO of 99.9% purity) with an average size of  $3\mu\text{m}$  was supplied by FLUKA AG Company, hexachloroplatinic acid ( $\text{H}_2\text{PtCl}_6 \cdot 6\text{H}_2\text{O}$ , 40%wt of Pt) was supplied by REIDEL- DE HAEN AG SEELZE - HANNOVER chemicals Ltd. On the other hand, glass and silicon wafer (111) sheets were used as substrates for the thin film preparation process.

### II. Procedure of nano-thin-film preparation

The preparation of nano-thin-films was carried out by manufacturing a pulsed laser deposition apparatus. Figure 1 shows the details of manufactured PLD apparatus, while Figure 2 shows the heating and rotating part in PLD system. The film deposition was achieved by using a Q-switched Nd: YAG laser (2<sup>nd</sup> harmonic generation with 532 nm, pulse width 7nsec, fluence energy  $2\text{ J/cm}^2$  and repetition rate of 6 Hertz).

The target was prepared by mixing 3 g of ZnO powder with 3ml ( $\text{H}_2\text{PtCl}_6$ ) solution. Then, the mixture was sintering with  $200^\circ\text{C}$  for 6 hour to get 4gm containing 4% weight percentage of Pt.

The pure ZnO and the doped powders compressing under 15Ton to get the final pellets of ZnO and Pt:ZnO of 2 cm diameter and 0.4 cm thickness. In deposition process, glass (optically) and silicon sheets (111 orientation, n-type conductivity, and resistivity of  $1.5\text{--}4\ \Omega\text{ cm}$ , were used as substrates. The glass area dimensions of  $(3 \times 2)\text{ cm}^2$ . The glass sheets were clean by ethanol with ultrasonic device for 15 minutes to remove any contaminants. On the other hand, silicon sheets of square-shaped  $1\text{ cm}^2$  were prepared by using a wire-cut machine. In addition, in order to remove any oxides the samples were etched with mixture of  $\text{HNO}_3$ ,  $\text{CH}_3\text{COOH}$ , and HF (called CP4A solution) at ratios 3:3:5 respectively. After that, samples were cleaned first by ethanol and followed by ultrasonic device for 15 minutes, after that cleaned by water and then another time for ultrasonic device for 15 minutes.

The distance between substrate and target kept constant at 4cm for all runs. The system chamber was kept constant at vacuum pressure of  $10^{-2}\text{ mbar}$ . The number of laser pulses was in the range of 10-400 with laser exposure time of 15-40 min. The laser deposition process was achieved at different temperatures of (200, 250, and  $300^\circ\text{C}$ ). Table 1 shows the main operating parameters of PLD process.

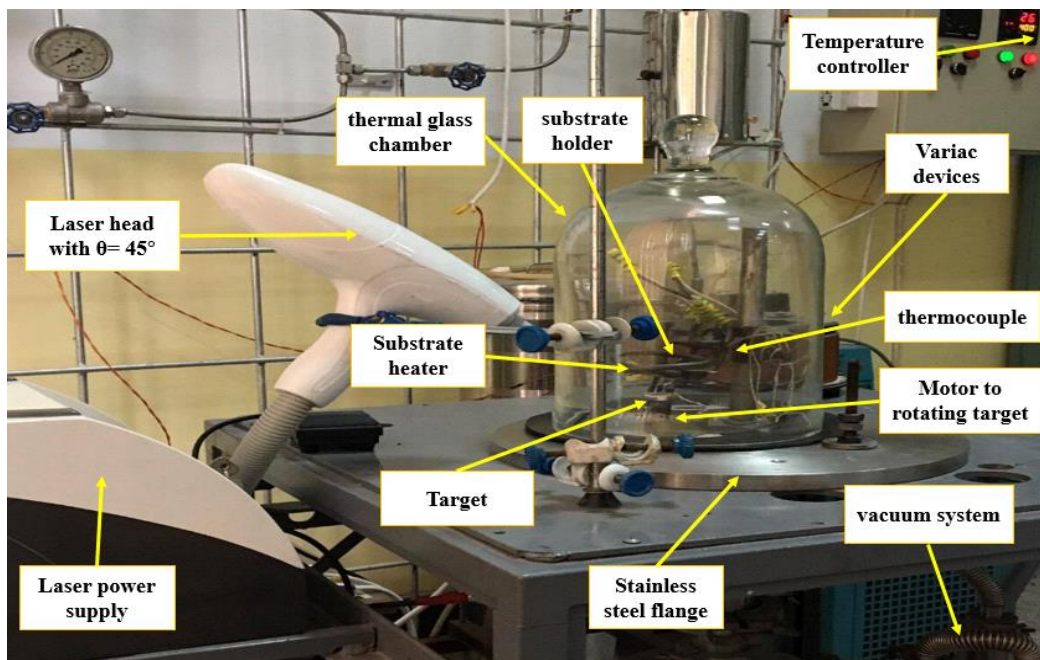

Figure 1: Experimental apparatus of the pulsed laser deposition (PLD).

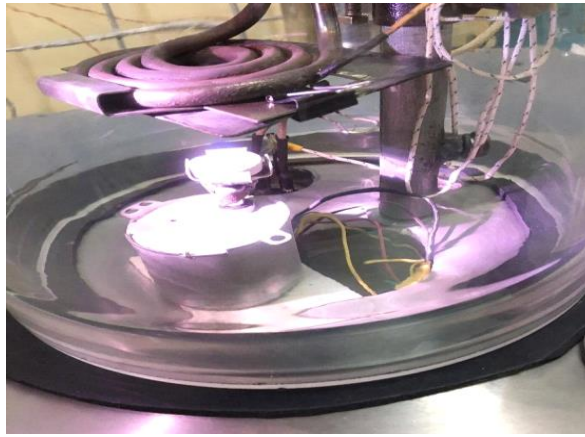

Figure 2: Details of heating and rotating part in the manufactured (PLD) system.

Table 1: Parameters of PLD system that used in the Present work

Parameters	Values	Parameters	Values
Laser fluence energy	2 J/cm <sup>2</sup>	Laser Angle	45°
Laser pulse duration	7ns		
Laser shoots	400 pulses	laser head to target distance	15cm
Target to substrate distance	4cm	Laser frequency	6 Hertz
Vacuum pressure	10 <sup>-2</sup> mbar	Substrate temperature	200, 250 and 300°C

### III. Film characterization and performance test

Many measuring techniques are used in the present work to characterize the prepared nano-thin-films; scanning electron microscope SEM-Tescan-VEGA3, atomic force microscope (AFM-SPM-AA-3000), UV Visible and X-ray diffraction (Shimadzu 6000-XRD). Optical interferometer was used to measure the prepared films thicknesses. The mechanism of this test depends on the interference theorem. In this mechanism, the light beam is reflected from film surface and substrate bottom. The wavelength of used Helium-Neon-laser is 632.8nm. Then, the film thickness can be calculated from the following formula [1,4].

$$t = \frac{\Delta x}{x} \times \frac{\lambda}{2} \quad (1)$$

where  $x$  is fringe width,  $\Delta x$  is the difference in the distance between two fringes and  $\lambda$  is the laser light wavelength.

The performance of prepared gas-sensors was measured by using performance test unit located at Ministry of Science and Technology-Material Research Office-Baghdad. The schematic diagram of unit is shown in Figure 3. The Liquefied Petroleum Gas (LPG) was selected to be the hydrocarbon test gas. The film was designed with active area of (1×1)cm<sup>2</sup>. The sample preparation method was based on silver electrodes after masking the electrodes area. Then, the prepared sensor was supported inside the test chamber and the process temperature was controlled by using a computerized control system. In addition, the unit of sensors

performance test included pressure regulators, refrigerated-air-dryer, and gases flow controllers. The air pressure and the test gas pressure were maintained at 1bar and the air flow rate was kept constant at 0.2l/min. The LPG flow rate was varied according to the required concentration of gas. Then, the performance of the sensor (Sensitivity) was calculated based on the following equation [12]:

$$\text{Sensitivity\%} = \left| \frac{(R_{\text{air}} - R_{\text{gas}})}{R_{\text{air}}} \right| \times 100 \quad (2)$$

where  $R_{\text{air}}$  or  $R_{\text{gas}}$  are resistance of the sensing material in the presence air or gas.

## 3. Results and Discussion

### I. X-ray diffraction

Figure 4 (a and b) shows X-ray diffraction patterns of pure ZnO powder and ZnO mixed with 4%wt of platinum metal (Pt:ZnO) respectively. It was noted that the main peaks of ZnO was location at 31.3, 34, 35.8 and 47.1 which correspond to the material phases (Mullers peaks) of (100), (002), (101) and (102) peaks respectively. The peaks shifted to be 31.8, 34.5, 36.3 and 47.7, which correspond to the (100), (002), (101) and (102) plans when ZnO mixed with 4%wt of Pt in Figure 4. It was concluded that the c-axis bond of platinum with the lattice was increased as the doping process increased. Therefore, it is expected increasing of peak intensities due to substitution of the platinum ions (122 pm diameter) into the zinc ions (71 pm) in the ZnO lattice [10].

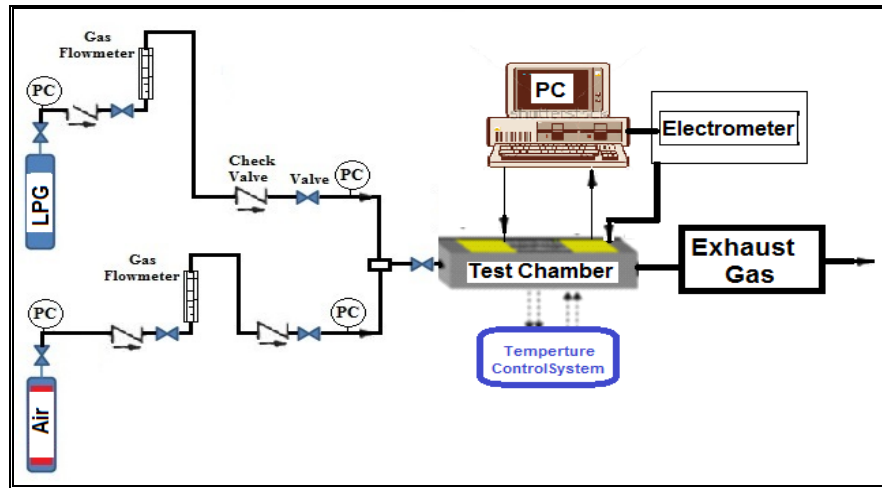

Figure 3: Schematic diagram of detection unit for gas sensor performance test

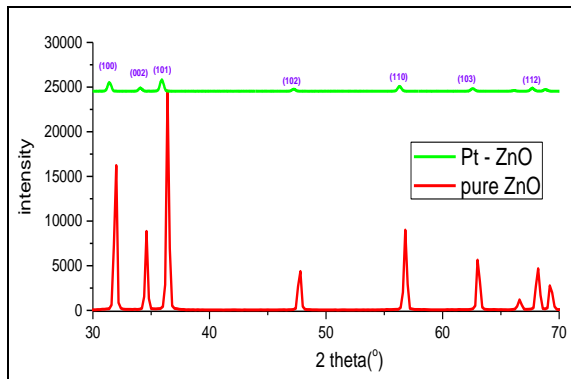

Figure 4: XRD of pure ZnO and Pt:ZnO

On the other hand, Figure 5 shows the effect of preparation temperature on the crystalline structure of Pt:ZnO. This figure demonstrated that the structure is amorphous at substrate temperature ( $T_s$ ) of 200°C. Then, as the value of ( $T_s$ ) was increased to 250°C (curve b) two peaks presented at 31.3 and 47.1 which are related to the peaks (002) and (102). Additionally, it was noted that when the temperature is raising to 300 °C (curve c), the peaks shape become sharper with higher intensity. Then, from XRD results it [14].

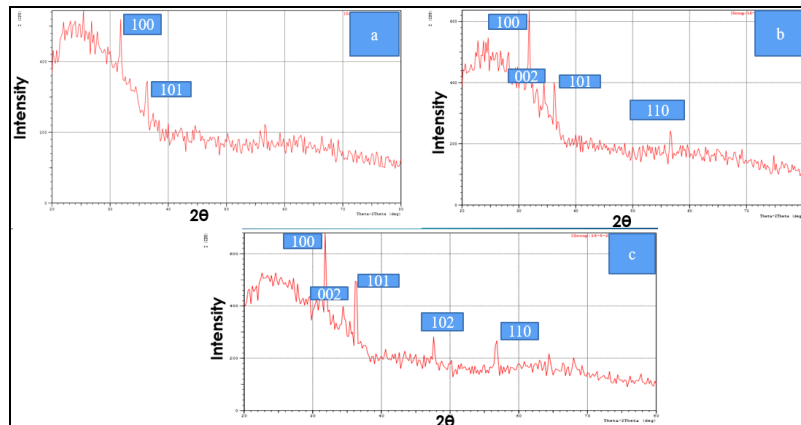

Figure 5: XRD spectra of Pt:ZnO / glass prepared at: a) 200°C b) 250°C, c) 300°C.

II. AFM results

Figure 6 shows the AFM images for the pure ZnO and Pt:ZnO thin films prepared at different temperatures of 200, 250 and 300 °C. From this figure, it can be noted that the topography of films deposited at 200 °C appears to be more uniform than that deposited at another temperatures (250 and 300°C). In addition, the root mean square (RMS) roughness was increased with increasing of deposition temperatures  $T_s$ .

The RMS roughness values at the three temperatures are (3.8, 4.6 and 8.4.2) nm (6.2, 8.2 and 10.3) for the ZnO and Pt:ZnO respectively as shown in section analysis. Table 2 summarized the numerical values of the effect of the substrate temperature on thin films results. It can be concluded that the grain size of films increased with increasing of temperature [14]. The best values for grain Size and RMS roughness was noted at preparation temperature of 250°C.

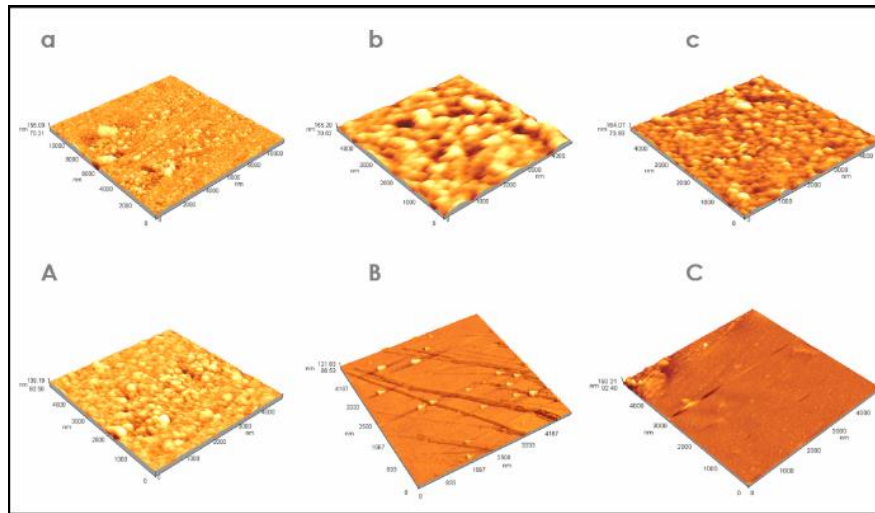

Figure 6: Three dimension AFM images of Pt:ZnO thin films deposited at A, a) 200°C, B, b) 250°C and C, c) 300°C

III. SEM results

Figure 7 shows the SEM images of Pt:ZnO films deposited at 200, 250 and 300°C respectively. It can be noted that the films have a uniform morphology without any holes at the surface. In addition, a homogeneous morphology it was seen

for films prepared at 200 and 250 °C with particles distribution of 30-80 nm. Then, as the substrate temperature increased to 300 °C the average particles size of aggregated particles increased too [8,12].

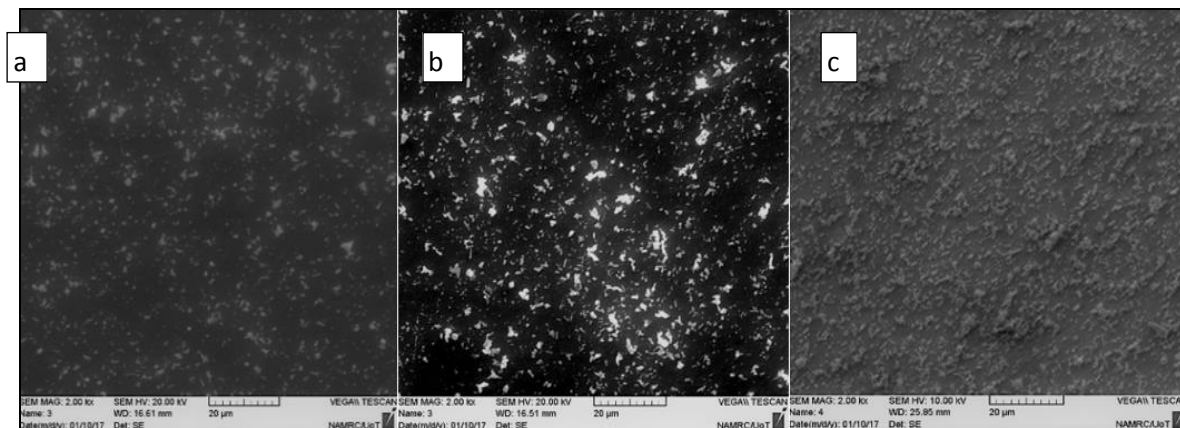

Figure 7: SEM image of the Pt:ZnO films prepared at: a) 200, b) 250, and c) 300°C.

Table 2: Effect of the substrate temperature on films specification.

T <sub>s</sub> (°C)	ZnO		Pt:ZnO	
	Grain size (nm)	Roughness (nm)	Grain size (nm)	Roughness(nm)
200	74	4.6	96	8.2
250	71	3.8	80	6.2
300	82	8.4	105	10.3

IV. UV and electrical specifications results

Figure 8 shows the UV results of Pt:ZnO in the range of (300–900)nm at different films preparation temperatures. It was concluded that the transmittance highly depending on the temperature. The average transmittances of the

films were about 90% in the visible and near-infrared wavelength. For all the films, it was concluded that the optical transmittance decreases slightly with increasing of preparation temperature. This behavior is in accord with the increasing of the surface roughness in which

come from the increasing of the surface scattering of the light.

Figure 9 shows the relationship between current and voltage (I/V) in dark in which represent the film electrical characteristics ZnO and Pt:ZnO at temperature of 250°C with and without LPG exposure respectively. The current with the ZnO/Pt film was higher than that of ZnO film, while, the resistance on the contrary of the current.

V. Gas sensors performance test 250°C

It was noted that the gas sensor sensitivity is highly dependent on the morphology and particles size of the films. The prepared films at temperature of 250°C lead to formation nanostructures in which possess a large surface area. Such behavior will be show more quantities and fractions of atoms or molecules on the surface. Then, according to adsorption mechanism of gas sensing, the reaction between adsorbent gas and active species of  $O^-$ ,  $O^{2-}$ ,  $H^+$ , and  $OH^-$  can be occur strongly on the surface of the film [5,12,16]. Therefore, according to results of figure 10 the Pt:ZnO film showed the best sensitivity toward LPG in comparison to that of ZnO film. Then, it can be concluded that the present of platinum in the film structure will be produce high surface area due to formation of Nano size platinum metal formed in the structure. In other words, the high surface area was generated from the distribution of Pt. particles in grain boundaries of ZnO nanostructure. Therefore, in this paper, such mixed behavior that generated from platinum and ZnO is called “Bifunctional behavior” which improve the sensing performance in direction of hydrocarbons.

Actually, in order to study the effect of LPG concentration dos on the performance of sensor sensitivity many LPG doses were investigated. The LPG concentrations were in the range of 30 to 300 ppm as shown in figure 11. Then, it was concluded that the sensors sensitivity is highly dependent on the LPG dos. Also, it is important to mention here that operating temperature is an important parameter in petroleum sector. Therefore, figure 12 illustrates the relationship between gas sensor sensitivity and operating temperature. Then, it can be noted that the sensing ability increases with increasing of operating temperature up to the maximum temperature of 300 °C. Then, the sensing ability falls with further increasing of the operating temperature. The high temperature operation lead to shorter life time of gas with extensive electricity cost. The best operating temperature

was concluded to be at 250 °C of performance testing unit.

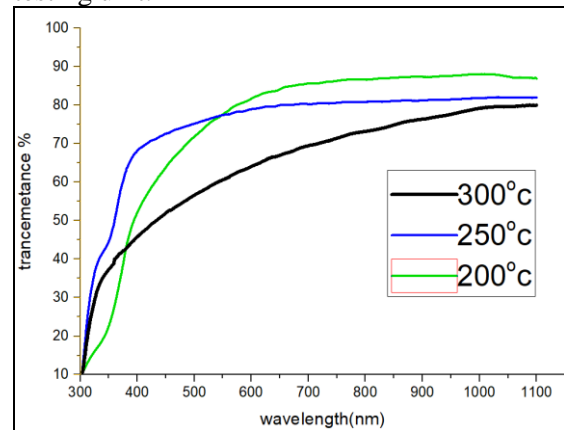

Figure 8: UV spectra of Pt:ZnO films prepared at: a)200, b) 250 and c) 300oC.

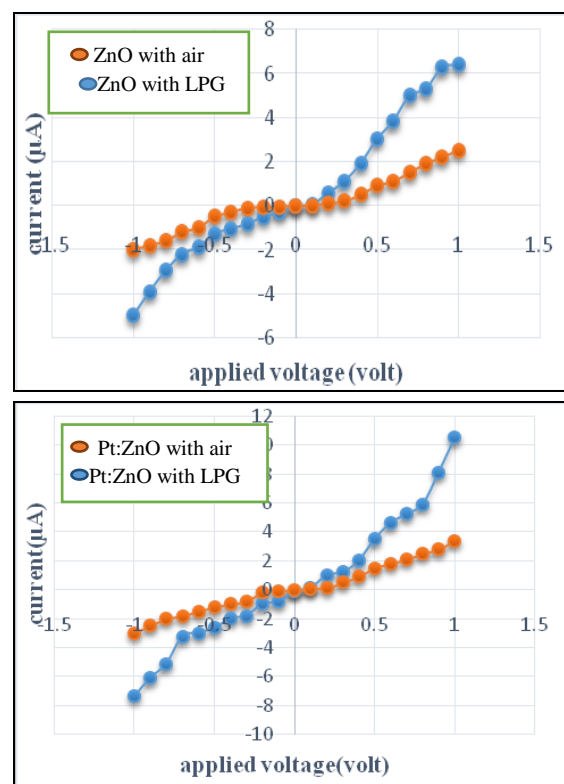

Figure 9: I/V curve in the dark with and without LPG exposure for a) ZnO, b) Pt:ZnO

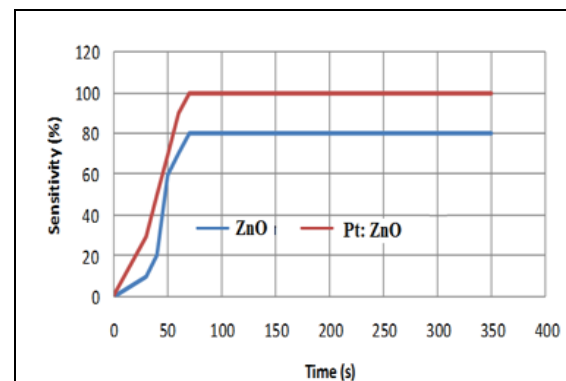

Figure 10: Gas sensitivity for pure ZnO and Pt:ZnO.

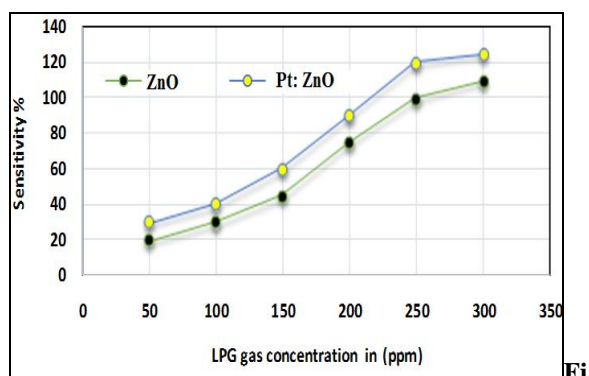

Figure 11: Sensitivity curve of the sensor with LPG gas concentration.

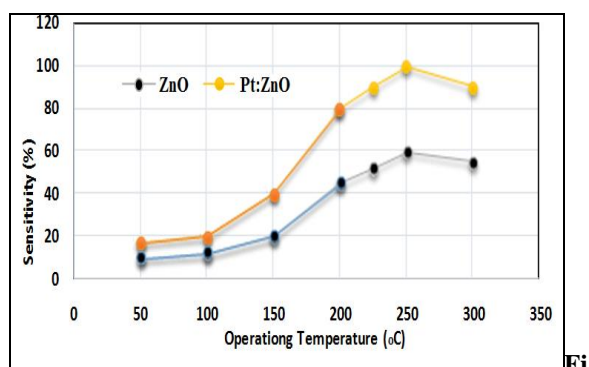

Figure 12: Sensitivity versus operating temperature at 250 ppm LPG

### 3. Conclusions

In this investigation a bifunctional nano-gas-sensor film Pt:ZnO was prepared successively with improved sensitivity to LPG of about 40% in comparison to parent nano-gas-sensor of ZnO. From the results of the film structure and morphology (XRD, SEM, and AFM) it was concluded that the best preparation temperature for (Pt:ZnO) film was 250 °C. All results pointed to that the crystalline structure of the film changed from amorphous to crystalline at higher temperature due to formation of nanostructured material with higher surface area. RMS roughness and grain size increased with increasing of film preparation temperature. On the other hand, UV results indicated that the prepared bifunctional film is more suitable for gas sensing applications due to of its higher transparent in the visible region with transmittance value of about 90%. The final bifunctional behavior of platinum and ZnO is improve the sensing performance in toward LPG hydrocarbons.

### Acknowledgements

The authors would like to thank the Laser and Optoelectronics Engineering Department and Nanotechnology and Advanced Materials Research Center in University of Technology for supporting this research.

### References

[1] V.V. Ganbavle, S. I. Inamdar, G.L. Agawane, J.H. Kim and K.Y.Rajpure, "Synthesis of fast response,

highly sensitive and selective Ni:ZnO based NO<sub>2</sub> sensor", Chem. Eng. Journal, Vol. 286, 15 Feb., 36-47, 2016.

[2] S.S. Barkada, D.V. Pinjari, U.T. Nakate, A.K. Singh, P.R.Gogate, J.B. Naik, S.H. Sonawance and A.B. Pandit, "Ultrasound assisted synthesis of polythiophene/SnO<sub>2</sub> hybrid nanolatex particles for LPG sensing", Chem. Eng. and Processing: Process Intensification, Vol. 74, Dec., 115-123, 2013.

[3] A.V.B. Reddy, Z. Ysuop, J. Jaafar, Y.V.M. Reddy, A. B. Aris, Z. Abdul Majid and J. Talib, G.Madhavi, "Recent progress on Fe-based nanoparticles: Synthesis, properties, characterization and environmental applications", Journal of Env. Chem. Eng., Vol. 4, Issue 3, Sep. 3537-3553, 2016.

[4] R. Kumar, G. Kumar, and A. Umar "Pulse Laser Deposited Nanostructured ZnO Thin Films: A Review" Journal of Nanoscience and Nanotechnology, Vol. 14, 1911-1930, 2014.

[5] K.A. Sukkar, A.J. Haider, S. Ahemad and K.Z. Yahya "Nanostructure Properties of Tin – Oxide on Sapphire Prepared by Pulsed Laser Deposition (PLD)" Proceeding of 1<sup>st</sup> Scientific Conference of Nanotechnology and Advanced Materials, University of Technology, Oct., Vol.1, 80-88, 2009.

[6] T. Seiyama and S. Kagawa, "Study on a Detector for Gaseous Components Using Semiconductive Thin Films", Anal. Chem. 38, 1069-1073, 196.

[7] S. Basu and P.K. Basu" Nanocrystalline Metal Oxides for Methane Sensors: Role of Noble Metals", Journal of Sensors, Vol. 861968, p 20, 2009.

[8] A. Ashrafia and C. Jagadish, "Review of Zinc Blende ZnO: Stability of Metastable ZnO Phases", Focused Review J. of Appl. Phys. 102, P. 071101, 2007.

[9] L. Gao, Q. Li, W. Luan, H. Kawaoka, T.Sekino, and K. Niihara "Preparation and Electric Properties of Dense Nanocrystalline Zinc Oxide Ceramics". J. Am. Ceram. Soc. 85:1016, 2002.

[10] M.G. Thakare, C.G. Dighavkar and J.S. Aher, "Effect of Pt Doping on ZnO Nanoparticles" International Journal of Recent Trends in Engineering & Research (IJRTER), Vol. 2, Issue 03, 2455-1457, 2016.

[11] H. Nanto, H. Sokooshi and T. Kawai, "Aluminum-Doped ZnO Thin Flm Gas Sensor Capable of Detecting Freshness of Sea Foods", Sens. Actuators B 14 715-717, 1993.

[12] S. Turner, S.M.F. Tavernier, G. Huyberegts, E. Biermans, S. Bals and K.J. Batenburg, "Assisted spray pyrolysis production and characterization of ZnO nanoparticles with narrow size distribution" J Nanopart Res, Vol. 12, 615-622, 2010.

[13] S. Saito, M. Miyayama, K. Koumoto and H. Yanagida," Gas sensing characteristics of porous ZnO and Pt/ZnO ceramics" J. Am. Ceram. Soc. 68 40-43, 1985.

[14] S.P. Ghosh, K.C. Das, N. Tripathy, G. Bose, T. Lee, J. M. Myoung and J.P. Kar, "Morphological and

Photoluminescence analysis of Zinc Oxide thin films deposited by RF sputtering at different substrate temperatures “ IOP Conf. Series: Materials Science and Engineering 75, 12023, 2015.

[15] E. Comini, G. Faglia, and G. Sberveglieri” Electrical-Based Gas Sensing in Solid State Gas Sensing” (Ed), Springer Science Business Media, LLC, New York, 2009.

[16] P. Nunes, E. Fortunato, A. Lopes and R. Martins, “Influence of the deposition conditions on the gas sensitivity of zinc oxide thin films deposited by spray pyrolysis”, Int. J. Inorg. Mater.3 1129– 1131, 2001.

[17] R.R. Salunkhe, D.S. Dhawale, D.P. Dubal and C.D. Lokhande “Sprayed CdO thin films for liquefied petroleum gas (LPG) detection” Sens. Actuators B 140 8691, 2009.

[18] M. Takata, D. Tsubone, and H. Yanagida, “Dependence of Electrical Conductivity of ZnO on Degree of Sensing,” J. Amer. Ceram. Soc., Vol. 59, 4–8, 1976.

[19] K. Ramamoorthy, C. Sanjeeviraja, M. Jayachandran, K. Sankaranarayanan, P. Misra, and L. M. Kukreja, Current Applied Physics,” Development of a novel high optical quality ZnO thin films by PLD for III–V opto-electronic devices” Volume 6, Issue 1, Pages 103-108, 2006.

[20] R.B. Ettliger, A. Cazzaniga, S. Canulescu, N. Pryds and J. Schou, “Pulsed laser Deposition from ZnS and Cu<sub>2</sub>SnS<sub>3</sub> Multi-component Targets”, Appl. Surf. Sci., Vol. 336, 385- 390, 2015.

#### Author(s) biography



Dr. Khalid A. Sukkar is an Asst. Professor in Chemical Engineering Department at the University of Technology, Iraq. He received his PhD in 2004 from the University of Technology, Iraq. His research interests include petroleum and gas industry, catalysts, transport phenomena, and nanotechnology applications.



Dr. Suad Mahmmod Kadim is a staff member in Laser and Optoelectronics Engineering Department at the University of Technology, Iraq. Her research interests include applied physics and nanotechnology.



Ahmed S. Falih is a student of M.Sc. in Laser and Optoelectronics Engineering Department at the University of Technology, Iraq. He received his BSc in in 2015 from University of Technology.