

فرص إقامة حاضنات الأعمال في العراق لدعم المشروعات الصغيرة

الخلاصة

%98

%80-40

Abstract

Business incubator is a new effective mechanism in developing small projects through its introductions of a new integral system of services. It aims at supporting and developing making new projects. Hence, there is a big number of factors that are interrelated in the processes of preparation for those projects. Those factors are: organizing the incubator and the market available for the projects attached to them and the work programs which will have to be implemented. Those small projects represent more than 98% of the total work institutions in the world. Also it has become responsible for a ration reaching half of the national output of those countries. These projects have created between 40 to 80% of job opportunities available. In light of their importance, these projects faced numerous challenges resultant of freeing markets due to globalization. Accordingly, there was a need to bring about a work system whose function is to develop and update the concept of supporting new projects. Business incubator is regarded as one of the best mechanisms ever invented in the last 20 years that support small projects. Such projects provide many services that maintain the natural continuity of the projects so as to avoid failure and collapse. Business incubator is the focus of deep interest for the advanced and developing countries, including Iraq.



المحور الاول / الاطار المفاهيمي لحاضنات الاعمال

:

Business Incubators

(1) ()

1959

))

(2) ((

"

(3)

)

(4)"

(5) (

(6)

-1

-2

-3

-4

-5

-6

-7

-8

-9

-10

-11



:

%88

(7)

2000

(96)

(2400)

(8)

(9)

" "

%27

%95

(10)

(1)

/

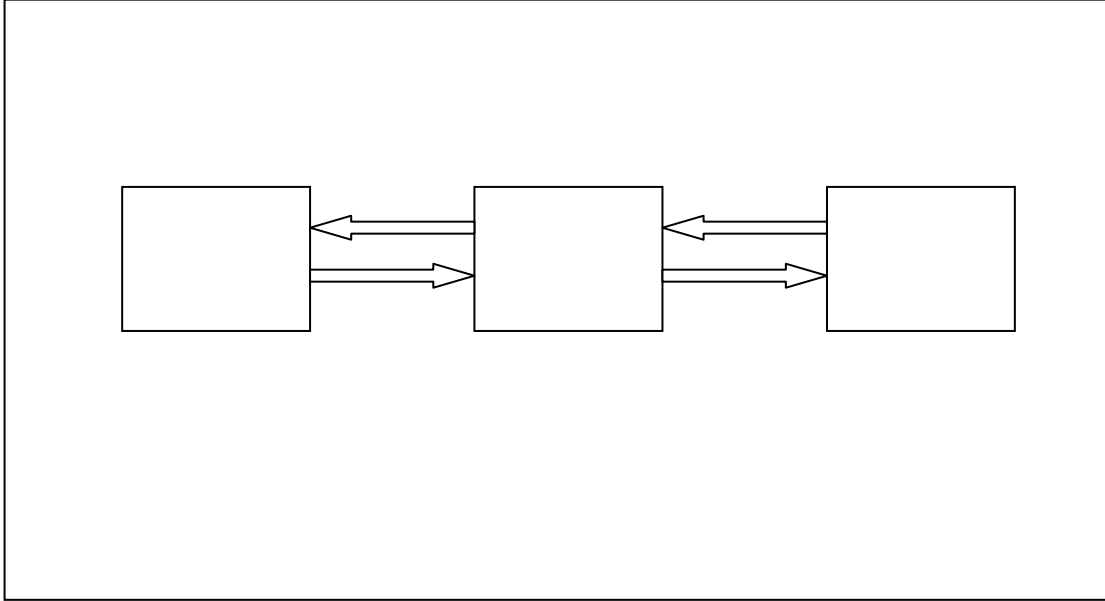

Patrick Crehan "Incubation Services " 8th science week, 17 December, 2002. Amman; Jordan,

:



(28)

%25-20

:

()

(29)

-1

(Technology Innovation)

(Innovation Process)

(30)

(31)

-2

(32)



(33)

(34)

-1

-2

-3

-4

(....

-5

-6

-7



			:
	:		:
	(35)		
(40)			
%75			
%25			
	(36)%100		- :
			:
	%50		
		%30	
		%20	
	(37)		- :
			:
	(38)		
		%100	
		(39)	



(40)

2003

(41)

الاستنتاجات

-1

-2

-3

-4

-5

-6

**التوصيات**

-1

)

(

-2

-3

-4

-5

-6



-	-				(1)
.27	2001		.411	2009	(2)
					(3)
	.5	2005	-	-	(4)
	.54	2004		2	(5)
10					(5)
http://www.google.aebusinessincubator.com :				4	2003
					(6)
				:	-
	.3	2004			-
	.22	2003			(7)
	.72	2003	-	-	(8)
	()		.17		(9)
	.55	2006			(10)
			.18		(11)
.21-20	2009	19-18		-	(12)
	.332	2002			(13)
			.612	2006	18-17
-17					(14)
			1018	2006	18
			.1018		(15)
	.333				(16)
			:		(17)
			.12	2000	
		:()			(18)
.57	2002			:	



- (19) . : 1
- .397 1997 (20) .
<http://www.eighad.com/read.asp> :
- (21) J. stiglitz:someieasons from the east asian miracle, world. Research observer,
 Vol. 11. No.2 August 1996, P; 154.
- (22) . :
 .20 1998
- (23) . .67
- (24) . .72
- (25) . -
- (26) . " 2010 -1950
 .8 2008
 .119 1995 -
- (27) . -
- (28) . .64 2005
 :
 .15 2005 -
- (29) . .82
- (30) . .44-43 2010 - 18
- (31) . : ()
- (32) . .7 2006
 2006 .19-18
- (33) . .20
- (34) . .1020-1019
- (35) . : ()
- (36) . .42 2001 12 3-1 -
 17 .
- (37) . .27 2008
 .31-30
- (38) . :
 .7 2005
- (39) . .31
- (40) . :
 .1 2001
- (41) . .218 2009