

DESIGN AND ANALYSIS OF A NEW PROSTHETIC FOOT FOR PEOPLE OF SPECIAL NEEDS

Dr. Kadhim K. Resan* Dr. Ali H., Al Hilli** and Muslim Muhsin Ali***

*University of AL-Mustansriyah/College of Engineering/Mechanical Engineering Department/Lecturer

**University of AL-Nahrain/College of Engineering/Mechanical Engineering Department/Lecturer

***Technical Institute- Babylon/ Mechanical Engineering Department/Assist Lecturer

ABSTRACT:

Loss of the lower limb can cause loss of mobility .At all places and at all times, efforts have always been made to make up for such a loss. The basis of this investigation is to research current prosthetic in order to design and build a more human like prosthesis. Also this investigation aims at combining these characteristics in order to achieve a more multi functional prosthesis. In undertaking such a design, the new prosthesis will be exhibit a broader range of characteristics than those displayed in current prosthetic feet. In doing so, the new prosthesis will enable a closer representation of the functions inherent of a normal human foot. The characteristics involved in normal walking include dorsiflexion, impact absorption and fatigue foot test. The characteristics displayed in the manufactured new foot tested were compared to those of SACH foot. The characteristics exhibited by prostheses which compared favorably to those of a human foot were investigated further. A new prosthetic foot is designed and manufactured from polyethylene and a comparison study with SACH foot was used to determine if there are differences in the gait pattern while wearing the NEW foot and whether these differences would be problematic. The basis of the new prosthetic design combines current prosthetic design elements, such as materials and components. The analytical part presents the results of the static and fatigue analysis by methods; numerical methods (Finite Element method FEM) and experimental methods. The new foot was designed and the number of cycle, dorsiflexion and impact were measured. The new prosthetic foot has a good characteristic when compared with the SACH foot, such as good dorsiflexion (7.8° - 6.4°), force transmitted at impact heel (9.82N-9.50N) and life of foot (2,103,445-896,213) cycles respectively.

Keyword: prosthetic foot, dorsiflexion, fatigue, impact, ANSYS program.

تصميم وتحليل قدم صناعي غير مفصلي لذوي الاحتياجات الخاصة

الدكتور: كاظم كامل رسن* الدكتور: علي حسين الحلبي** السيد: مسلم محسن علي***

*جامعة المستنصرية/كلية الهندسة/ قسم الميكانيك

**جامعة النهرين/كلية الهندسة/ قسم الميكانيك

***المعهد التقني بابل/ قسم الميكانيك

الخلاصة:

أن فقدان إحدى الساقين قد يؤدي بالمصاب الى البقاء طريح الفراش . و لطالما حاول الإنسان ، على مر العصور ، أن يجد بديلاً يحل محل الطرف المفقود. وعليه فقد تناول هذا البحث إجراء عدة تغييرات على تصميم قدم صناعية جديدة لمحاكاة القدم الطبيعية للإنسان وكذلك تم التداخل فيما بين الخصائص العامة للقدم المصنعة في محاولة للحصول على قدم متعددة المهارات وبهذا أظهرت القدم الجديدة المصنعة مدى واسع من الخصائص أكثر مما هو عليه في الإقدام الصناعية في البحوث السابقة. مما جعل القدم الجديدة المصنعة تقترب من حيث كافة الخواص الميكانيكية للقدم الطبيعية، ومن أهم تلك الخصائص السير الطبيعي متضمناً الانحناء الطولي ومعدل امتصاص طاقة الصدمة واختبارات عمر الكلال لتلك القدم.

كما وتم في هذا البحث مقارنة كافة الخصائص الميكانيكية للقدم الجديدة المصنعة مع ما يسمى بال (SACH Foot) والتي بدورها تعتمد أساساً على محاكاة قدم الإنسان الطبيعي. تم في البحث أيضاً بتصميم وتصنيع قدم صناعية من مادة البولي إثيلين عالي الكثافة ومقارنتها مع إل (SACH Foot) وملاحظة الفروقات في هيئة المشي ومقدار البلى وهل إن تلك الفروقات ستكون بمثابة مشكلة تتطلب إيجاد حلول لها. كما تم دمج كافة العناصر المؤثرة في تصميم القدم الصناعية مثل نوع المادة المصنعة منها وباقي المكونات الأخرى لتحسين التصميم بما يلائم استخدامها. كما تم في الجزء التحليلي العددي استعراض النتائج في اختبارات الكلال باستخدام طريقة العناصر المحددة (Ansys 11) وباستخدام كلا الطريقتين تم حساب عمر الكلال للقدم والإنهاء الطولي ومقدار امتصاص طاقة الصدمة. بمقارنة النتائج النهائية للقدم المصنعة مع إل (SACH Foot) كانت النتائج انحناء طولي بمقدار 7.8 و 6.4 للقدم الجديدة وال (SACH Foot) على الترتيب. القوة المنقولة في اختبار الصدمة (9.50N – 9.82N) وعمر الكلال للقدم (2103445 – 896213) دورة.

1- INTRODUCTION

Current prosthetic foot designs do not replicate the exact characteristics of a normal human foot. A human foot is a multi - functional device that can be used to perform a wide range of activities, however, a prosthetic foot is limited to only a few. More recently, manufacturers of prosthetic feet have looked into the characteristics of a prosthesis that may be adjustable. The amputee may then be able to perform a number of activities without requiring a different prosthesis.

Daher in 1975 [1] conducted an extensive investigation in which nine types of SACH feet were subjected to cyclic testing to assess the durability of the materials and design of the foot until breakdown occurred, the foot was cycled for 500,000 cycles at a load which simulated an active amputee weighing approximately 100 Kg, Figure (2-1). Also he found that major permanent deformation and changes in resistance at the heel occurred within only 5,000 cycles.

Wevers and Durance [2] in 1987 also conducted dynamic testing on prosthetic SACH feet, but they loaded the whole trans-tibial prostheses not the foot alone. Their results were similar to **Daher's** with rapid wear and structural component failures of the feet at less than 100,000 cycles.

R. Deval [3] stressed the importance of testing the durability of the prosthetics components. The report on the Seattle foot explains how it also obtains load – deflection characteristics as a part of the structural analysis to develop the right combination of Thermoset and thermoplastic matrices and reinforcements.

Toh et al. [4] avoided the complex loading. They utilized a simple machine which did not mimic gait but applied cyclic vertical loads to the heel and forefoot only. The feet were dynamically tested. Both the heel and toe were tested with sinusoidal cyclic axial loads peaking at 1.5 times body weight at 2 HZ for up to 500,000 cycles. Static load deflection tests were conducted between cyclic runs to detect mechanical property changes in the foot. Their results were on the Lammbda foot and Kingsley SACH foot.

A report by **Kabra et al.** [5] states the utilized a simple, low cost machine to fatigue the Jaipur foot, similar to **Toh's** device, however it appears to only simulate fast loading. A load-deflection analysis was also performed using a siling which passes around the foot, connects to a spring balance and read the not acting force while the degree of movement was reads from a goniometer the authors report these simple testing machines deliver reproducible results and yet another method of laboratory testing

should be considered. Shock absorption has been acknowledged as an important feature when used to compare different types of prosthetic feet.

Andrew H. Hansen et al. [6] investigated the effective foot length ratio (EFLR) for different feet such as Niagara foot and Flex foot, the EFLR multiplied by 100 provides the percentage of a foot. Effective foot lengths were measured by finding the distance from the heel of each prosthetic foot to the centre of pressure. The EFLRs for the prosthetic feet were between 0.63 and 0.81.

Anne Schmitz in 2007 [7] used a Niagra foot model with finite element methods (FEM) to analyze mechanical properties. The stiffness responses of the heel and toe off were measured using ISO 10328 by applying displacements at a rate of 5mm/minute through a load platen angled at 15° and 20° on the heel and toe, respectively. The maximum force applied was 1600 N.

The main aims of this paper may be summarized in the following points:

1. Design and manufacture a new prosthetic foot that resists fatigue failure and exhibits an excellent dorsiflexion.
2. Check impact energy absorption, which is used to determine heel foot properties.
3. Measure dorsiflexion angle of the NEW foot and compare the obtained value with that of the SACH foot.
4. Obtain fatigue failure life, which is used to predict the NEW foot life.
5. Finally, contribute to humanity comfort by providing suitable supplements to prosthesis.

3- The Suggested New Foot Design

One of the more conventional types of prosthetic feet is the SACH foot. There are numerous prosthetic foot designs available. These prosthetics feet serve basic functions which include: support the body against gravity during standing and walking; absorb shock during heel contact and in some cases mimic metatarsal esophageal function during the stance phase of gait, preventing the fatigue failure, storing energy as the stance limb accepts body weight and returns this energy as the foot lift off the ground and good lifts off the ground and good dorsiflexion. The material chosen for the newly designed foot was a polyethylene compound.

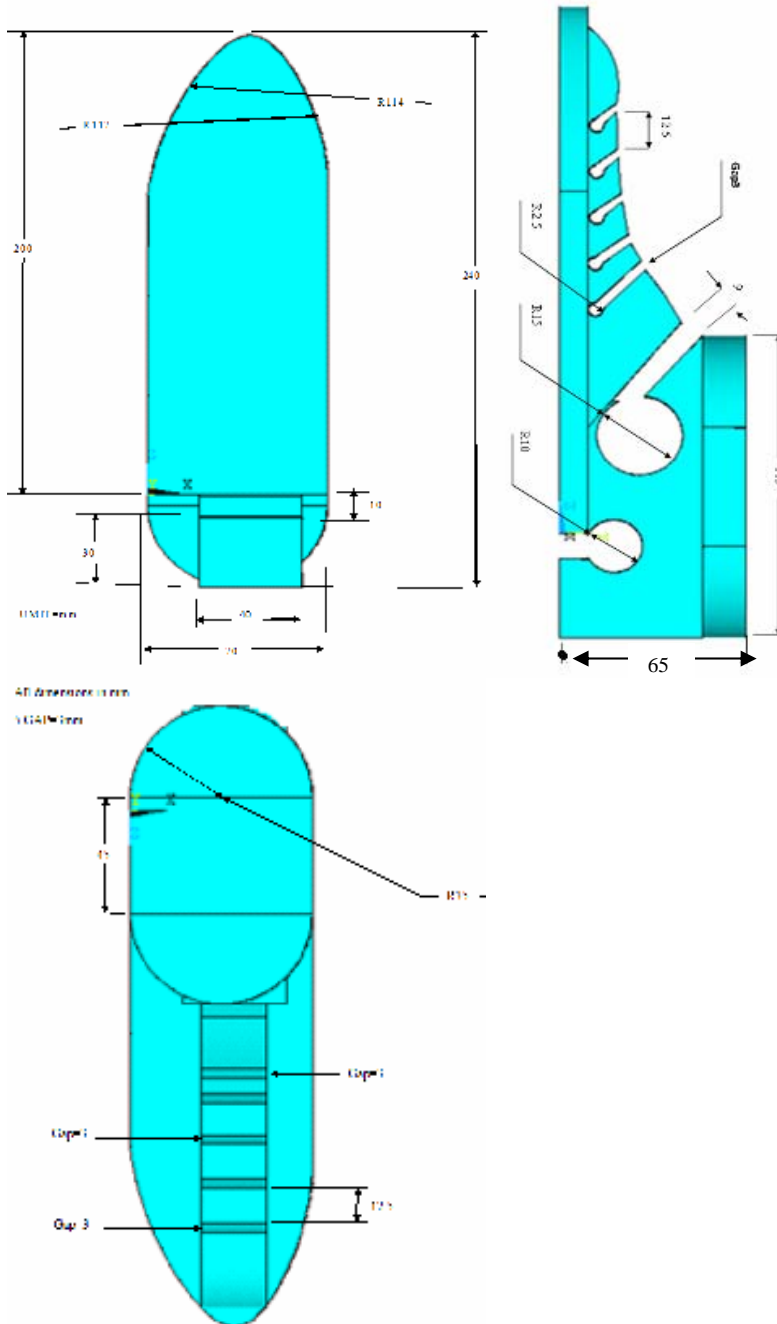

Fig. 1 back, front and top view of NEW foot.

In this paper. After optimizing the design and taking in the consideration the ability for manufacturing the NEW foot, design was drawn and analyzed with the finite element package (ANSYS). [Fig. (1)] The NEW foot was checked with the ANSYS and the development in the shape was continued until the fair shape was reached. A foot was manufactured and first prototype was produced, then simple machining processes were used to get final shape of products. The NEW foot was examined to find out such characteristics as dorsiflexion, dissipating impact energy, life, weight and cost.

4- Modeling of Prosthetic Foot Using ANSYS Software

The finite element method has become a powerful tool for the numerical solution of a wide range of engineering problems. The use of ANSYS-11 to create the finite element model is adopted [8]. The meshing process has been done by choosing the volume and the number of elements in each body, as shown in Figure (2). The number of elements was (10290) elements with total number of nodes of (20580) nodes.

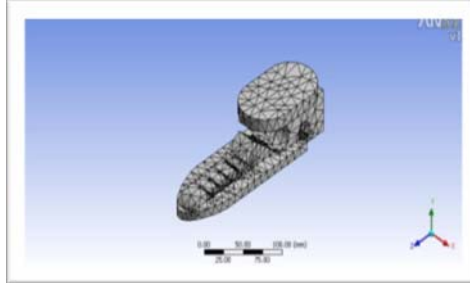

Fig. 2 NEW foot keel with mesh.

5- EXPERIMENTAL WORK

Many experimental tests are recommended for designing and manufacturing the artificial limb. The presented foot is new, and then it is important to examine the design, so that, a full size prototype is manufactured.

The dorsiflexion foot tester, Figure (3) were designed and built specially to examine the foot dorsiflexion. It consists of:

- 1- Frame (wood).
- 2- Shaft (steel).
- 3- Standards disk masses (Cast iron).
- 4- Triangle wood (20°).

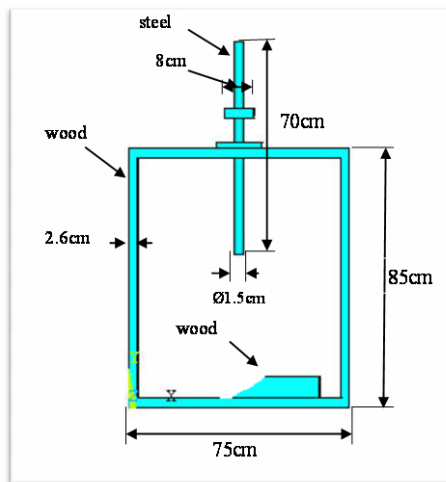

Fig. 3 Dorsiflexion foot tester.

5-1 Fatigue Foot Test

The SACH foot is placed on the fatigue tester in order to obtain the life of the foot. This procedure is applied to the NEW foot to compare between two lives. The load is alternative in order to simulate normal gait.



Fig. 4 Fatigue foot tester of SACH foot and NEW foot.

5-2 Dorsiflexion Test

To complete the dorsiflexion test the triangular wood (20°) must be manufactured and supported with graded ruler, Figures (5). This piece of wood is put in new dorsiflexion foot tester machine. It's replaced under crosshead.



Fig. 5 Dorsiflexion tester of SACH foot and NEW foot.

5-3 Impact Test: Heel Region Properties of Prosthetic Feet

To measure the shock absorption properties of the prosthesis at heel strike and estimate the contact time of the prosthesis with the force plate, measure which prosthesis has the best shock absorption properties at heel strike. To measure the heel region properties of prosthetic feet in response to impact, a pendulum was constructed to mechanically simulate the conditions immediately following initial heel-ground contact during walking.



Fig. 6 Impact foot tester of NEW foot.

6- RESULTS AND DISCUSSION

6-1 Mechanical Properties

The mechanical properties of all material are shown in Table (1).

Table 1 Mechanical properties of polyethylene [9].

MATERIAL	σ_y (MPa)	σ_{ULT} (MPa)	E (Gpa)
POLYETHYLEN	16.52	28.3	1.32

6-2 S-N Curve of Polyethylene

The curve of stress range S(MPa) against N(cycle) is produced.

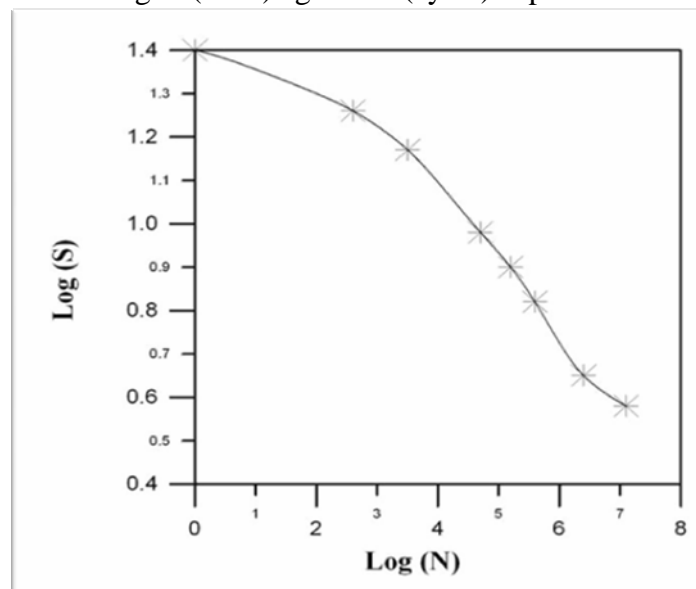

Figure 7 S-N curve for polyethylene [9].

Figure (7) shows the stress with number of cycles, these results are used in ANSYS software to examine a NEW foot life numerically.

6-3 Experimental Results Obtained from Foot

6-3-1 Fatigue Foot Tester Results

In order to determine the validity of the NEW foot fatigue tester in comparison to other testers currently being used, the industry standard SACH foot was tested in one of the test stations in order to determine its time failure. The SACH foot removed from the tester at 896,213 cycles was placed on the tester within a few months of manufacturing. This may indicate the material degradation is a factor in the life expectancy of SACH feet; using of wood and rubber in manufacturing the designed SACH foot. however, further testing would have to be undertaken. The NEW foot failure occurred in one specimen at 2,103,445 cycles as shown in Figure (8).

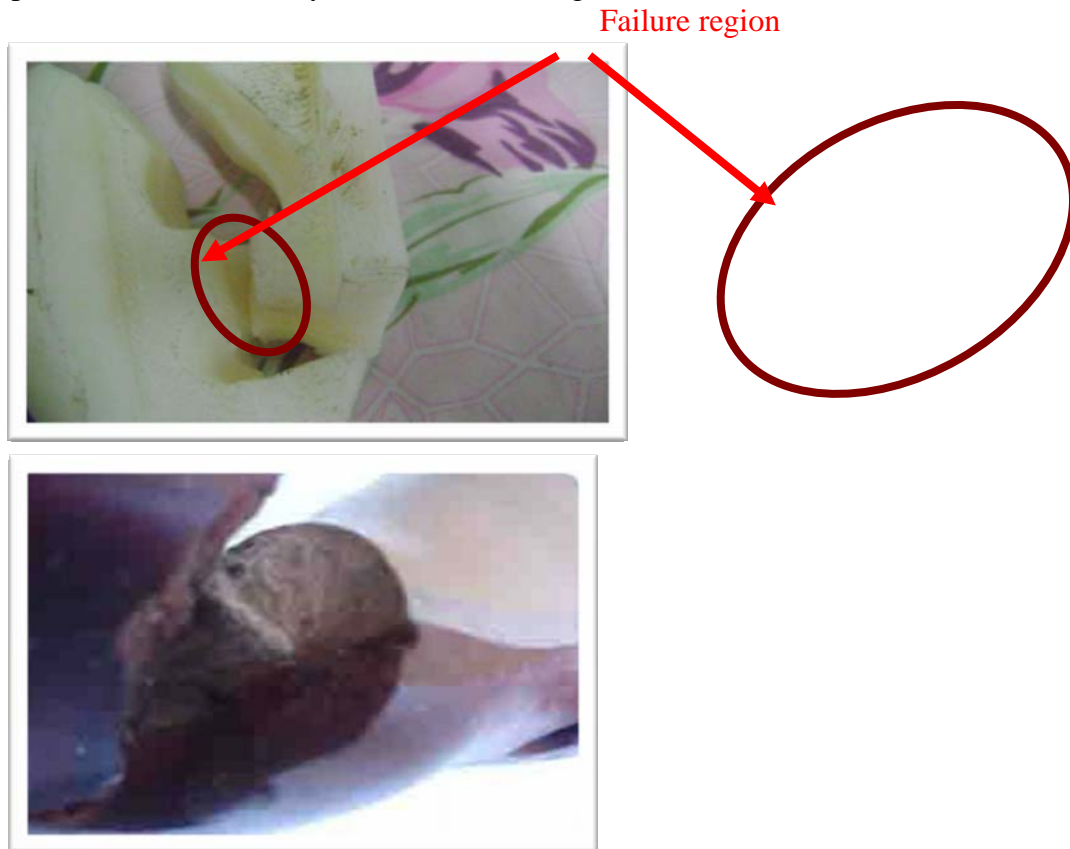

Fig. 8 Failure region in New foot and SACH foot.

Table 2 Life of different feet.

TYPE OF FOOT	LIFE OF FOOT (CYCLE)
SACH	896,213
NEW FOOT	2,103,445

6-3-2 Dorsiflexion

The dorsiflexion angles were experimentally obtained using a digital camera. The maximum dorsiflexion angles for normal human foot, SACH foot, and NEW foot are tabulated in Table (5-4).

Table 3 Dorsiflexion angle for different types of feet (load =846 N).

TYPE OF FOOT	DORSI-FLEXION ANGLE
Normal Human Foot	4.2°

SACH Foot	6.4°
NEW FOOT	7.8°

6-3-3 Impact for Heel Foot

Table (3) summarizes these results of impact foot. The impact response at heel strike reveal the SACH foot to have the largest peak force, followed in order by the NEW foot.

Table 4 Impact force with different types of feet.

Type of foot	Force read in load cell indicator [kgf]
SACH	9.5
NEW foot	9.82

6-4 Numerical Analysis Results

6-4-1 Static Analysis

The aim of this analysis is to investigate the stresses and deformations of clamped NEW foot with force after assuming that this value is the average of applied load (86kg or 846N). Figure (9) shows the Von-Mises stresses for presented foot is plotted versus foot length where foot toe-off is pointed as zero for the toe off phase. Zero stress will be gradually increase as with length until reaching the location of big hole then it will be decreased because of increasing section dimension, again it will be increasing until reaching the heel hole, then it will be decreased reaching zero at the heel end.

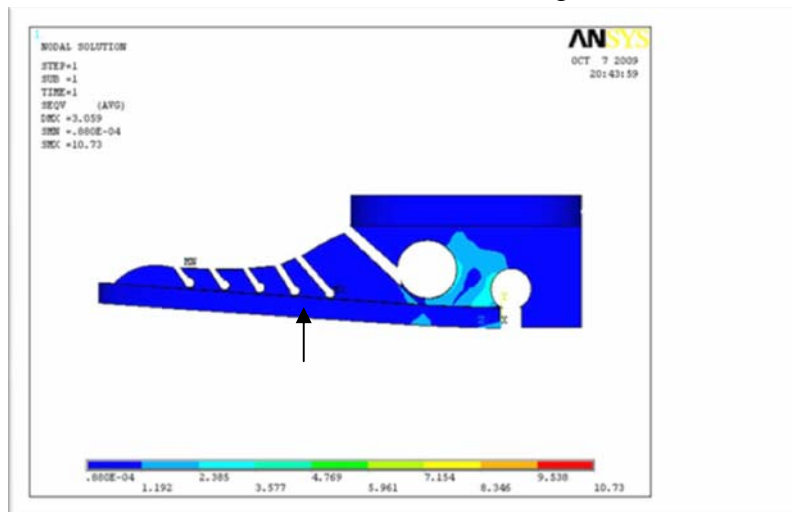

Fig. 9 Von-Mises stress contour of the NEW foot (toe off phase).

6-4-2 Fatigue Analysis.

The aim of this analysis is to investigate the fatigue of clamped NEW foot with force of (846N).

Figure (10) shows the maximum equivalent stress – safety factor for the internal side of the NEW foot. It can be seen from the figure that the maximum equivalent stress – safety factor is located in the heel hole tension side. The current configuration of the fatigue tester is such that it applies a known force using two pneumatic cylinders, one at heel and the other at toe, to simulate walking with a prosthetic foot. The main problem with this concept is that force is not applied during the whole stepping process. But rather is applied at the two extremes of the cycle. By concentrating the ground reaction force to two locations, artificial wear regions are created at the point of application of the heel and toe cylinder.

Recall that a complete gait cycle is the period between the heel strikes of one foot to the next strike of same foot. By testing only at heel strike and toe-off, this phenomenon cannot be simulated as artificial wear points will occur at the location of impact of heel strike and toe off rather than be transmitted throughout the complete stance phase of gait cycle. Cyclic testing is a valid method for evaluating the performance of prosthetic feet. The results obtained from the fatigue testing show that the SACH foot, old SACH and new foot design, which have a significantly stiffer heel bumper with an application force 846N, have the ability to withstand the shearing forces placed upon the prosthetic feet at heel strike without delimitation occurring or cracks developing. It underwent the fatigue process without delimitation occurring and failure was postponed. It appears that the interface of foam / rubber of the heel bumper suffers from distorting proximally at heel strike, this decreases the shear forces in this region. The SACH failed at the end of keel because of degradation in keel manufactured from wood without dorsiflexion in the ankle. The NEW foot failed at more cycles than SACH foot did because it contains multi arc's ankles, and keels, which double dorsiflexion and the material properties for polyethylene, become better than those of rubber foam.

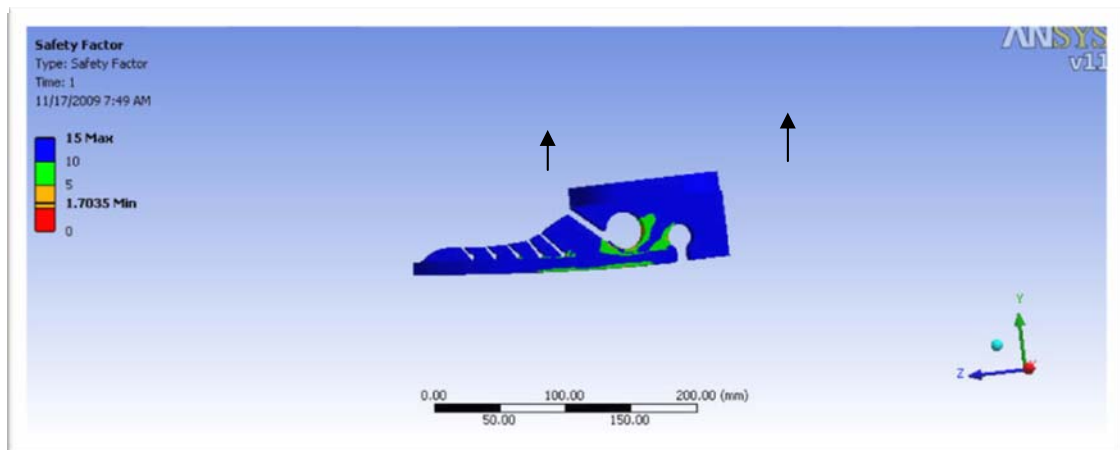

Fig. 10 Maximum equivalent stress contour – Safety Factor of the NEW foot for fatigue load.

7.1 CONCLUSIONS

The aim of this paper is to design a prosthetic foot that incorporates componentry from currently available prosthetic feet. From the results obtained both theoretically and experimentally the following conclusion can be drawn:

1. Using of high density polyethylene (PEHD) in manufacturing the designed NEW foot gives high dorsiflexion angle and long fatigue life but the approximately same impact energy absorption compared with SACH foot.
2. The dorsiflexion angle for the NEW foot is greater than that of the SACH foot, so it may give a bend up to an acceptable limit.
3. Lengthening the supporting keel along the whole length of the NEW foot gives the best stability to gait profile and long fatigue life.
4. The special design with slotted region on the upper side of the NEW foot makes an increment in dorsiflexion angle so it leads to more flexibility in gait profile.

5. The life (cycles) of NEW foot is longer than that of the SACH foot.

7-1 REFERENCES

- 1- **Daher R.L.** "Physical Response of SACH Feet under Laboratory Testing", Bulletin of Prosthetics Research, Vol.10, No.23, pp.4-50, 1975.
- 2- **Wevers, H.W and Durance J.P.** " Dynamic testing of Below –Knee Prosthesis: assembly and Components " J. of Prosthetics and Orthotics International, 11, pp.117-123,1987.
- 3- **R. Deval** "The Seattle Foot" J.oF Orthotics and Prosthetics Vol.40, No.8, pp.17-23, 1986.
- 4- **Toh S. L. , Goh J.C., Tan P. H. and Tay T.E.** "Fatigue Testing of Energy Storing Prosthetics and Orthotics International, 17, pp.180 -188, 1983.
- 5- **Kabra S. and Narayanan R.** " Equipment and Methods for Laboratory Testing of Ankle – Foot Prostheses as Exemplified by the Jaipur Foot " J. of Rehabilitation Research and Development, Vol.28, No.3, pp.23-34 , 1991.
- 6- **Andrew H. Hansen, Michel Sam and Dudley S. Childress** " The Effective Foot Length Ratio: A Potential Tool for Characterization and Evaluation of Prosthetic Feet " , J. of American Academy of Orthotics and Prosthetists , Vol.16, No.2, pp. 41-45, 2004.
- 7- **Anne Schmite** (nee Bans) "Stiffness Analyses for the Design Development of a prosthetic foot ", M.Sc thesis, University of Wisconsin-Madison, 2007.
- 8- **Bathe, K.J.,**1996,"Finite Element Procedure' Prentice Hall International Inc., USA, PP 1037.
- 9- **Kadhim K. Resan Al-Kinani,** "Analysis and Design Optimization of Prosthetic Below Knee" Ph.D., College of Engineering, Technology University, 2007.

كما وتم في هذا البحث مقارنة كافة الخصائص الميكانيكية للقدم الجديدة المصنعة مع ما يسمى بال (SACH Foot) والتي بدورها تعتمد أساساً على محاكاة قدم الإنسان الطبيعي. تم في البحث أيضاً بتصميم وتصنيع قدم صناعية من مادة البولي أثيلين عالي الكثافة ومقارنتها مع إل (SACH Foot) وملاحظة الفروقات في هيئة المشي ومقدار البلى وهل إن تلك الفروقات ستكون بمثابة مشكلة تتطلب إيجاد حلول لها. كما تم دمج كافة العناصر المؤثرة في تصميم القدم الصناعية مثل نوع المادة المصنعة منها وباقي المكونات الأخرى لتحسين التصميم بما يلائم استخدامها. كما تم في الجزء التحليلي العددي استعراض النتائج في اختبارات الكلال باستخدام طريقة العناصر المحددة (Ansys 11) وباستخدام كلا الطريقتين تم حساب عمر الكلال للقدم والإنهاء الطولي ومقدار امتصاص طاقة الصدمة. بمقارنة النتائج النهائية للقدم المصنعة مع إل (SACH Foot) كانت النتائج انحناء طولي بمقدار 7.8 و 6.4 للقدم الجديدة وال (SACH Foot) على الترتيب. القوة المنقولة في اختبار الصدمة (9.50N – 9.82N) وعمر الكلال للقدم (2103445 – 896213) دورة.

1- INTRODUCTION

Current prosthetic foot designs do not replicate the exact characteristics of a normal human foot. A human foot is a multi - functional device that can be used to perform a wide range of activities, however, a prosthetic foot is limited to only a few. More recently, manufacturers of prosthetic feet have looked into the characteristics of a prosthesis that may be adjustable. The amputee may then be able to perform a number of activities without requiring a different prosthesis.

Daher in 1975 [1] conducted an extensive investigation in which nine types of SACH feet were subjected to cyclic testing to assess the durability of the materials and design of the foot until breakdown occurred, the foot was cycled for 500,000 cycles at a load which simulated an active amputee weighing approximately 100 Kg, Figure (2-1). Also he found that major permanent deformation and changes in resistance at the heel occurred within only 5,000 cycles.

Wevers and Durance [2] in 1987 also conducted dynamic testing on prosthetic SACH feet, but they loaded the whole trans-tibial prostheses not the foot alone. Their results were similar to **Daher's** with rapid wear and structural component failures of the feet at less than 100,000 cycles.

R. Deval [3] stressed the importance of testing the durability of the prosthetics components. The report on the Seattle foot explains how it also obtains load – deflection characteristics as a part of the structural analysis to develop the right combination of Thermoset and thermoplastic matrices and reinforcements.

Toh et al. [4] avoided the complex loading. They utilized a simple machine which did not mimic gait but applied cyclic vertical loads to the heel and forefoot only. The feet were dynamically tested. Both the heel and toe were tested with sinusoidal cyclic axial loads peaking at 1.5 times body weight at 2 HZ for up to 500,000 cycles. Static load deflection tests were conducted between cyclic runs to detect mechanical property changes in the foot. Their results were on the Lammbda foot and Kingsley SACH foot.

A report by **Kabra et al.** [5] states the utilized a simple, low cost machine to fatigue the Jaipur foot, similar to **Toh's** device, however it appears to only simulate fast loading. A load-deflection analysis was also performed using a siling which passes around the foot, connects to a spring balance and read the not acting force while the degree of movement was reads from a goniometer the authors report these simple testing machines deliver reproducible results and yet another method of laboratory testing

should be considered. Shock absorption has been acknowledged as an important feature when used to compare different types of prosthetic feet.

Andrew H. Hansen et al. [6] investigated the effective foot length ratio (EFLR) for different feet such as Niagara foot and Flex foot, the EFLR multiplied by 100 provides the percentage of a foot. Effective foot lengths were measured by finding the distance from the heel of each prosthetic foot to the centre of pressure. The EFLRs for the prosthetic feet were between 0.63 and 0.81.

Anne Schmitz in 2007 [7] used a Niagra foot model with finite element methods (FEM) to analyze mechanical properties. The stiffness responses of the heel and toe off were measured using ISO 10328 by applying displacements at a rate of 5mm/minute through a load platen angled at 15° and 20° on the heel and toe, respectively. The maximum force applied was 1600 N.

The main aims of this paper may be summarized in the following points:

1. Design and manufacture a new prosthetic foot that resists fatigue failure and exhibits an excellent dorsiflexion.
2. Check impact energy absorption, which is used to determine heel foot properties.
3. Measure dorsiflexion angle of the NEW foot and compare the obtained value with that of the SACH foot.
4. Obtain fatigue failure life, which is used to predict the NEW foot life.
5. Finally, contribute to humanity comfort by providing suitable supplements to prosthesis.

3- The Suggested New Foot Design

One of the more conventional types of prosthetic feet is the SACH foot. There are numerous prosthetic foot designs available. These prosthetics feet serve basic functions which include: support the body against gravity during standing and walking; absorb shock during heel contact and in some cases mimic metatarsal esophageal function during the stance phase of gait, preventing the fatigue failure, storing energy as the stance limb accepts body weight and returns this energy as the foot lift off the ground and good lifts off the ground and good dorsiflexion. The material chosen for the newly designed foot was a polyethylene compound.

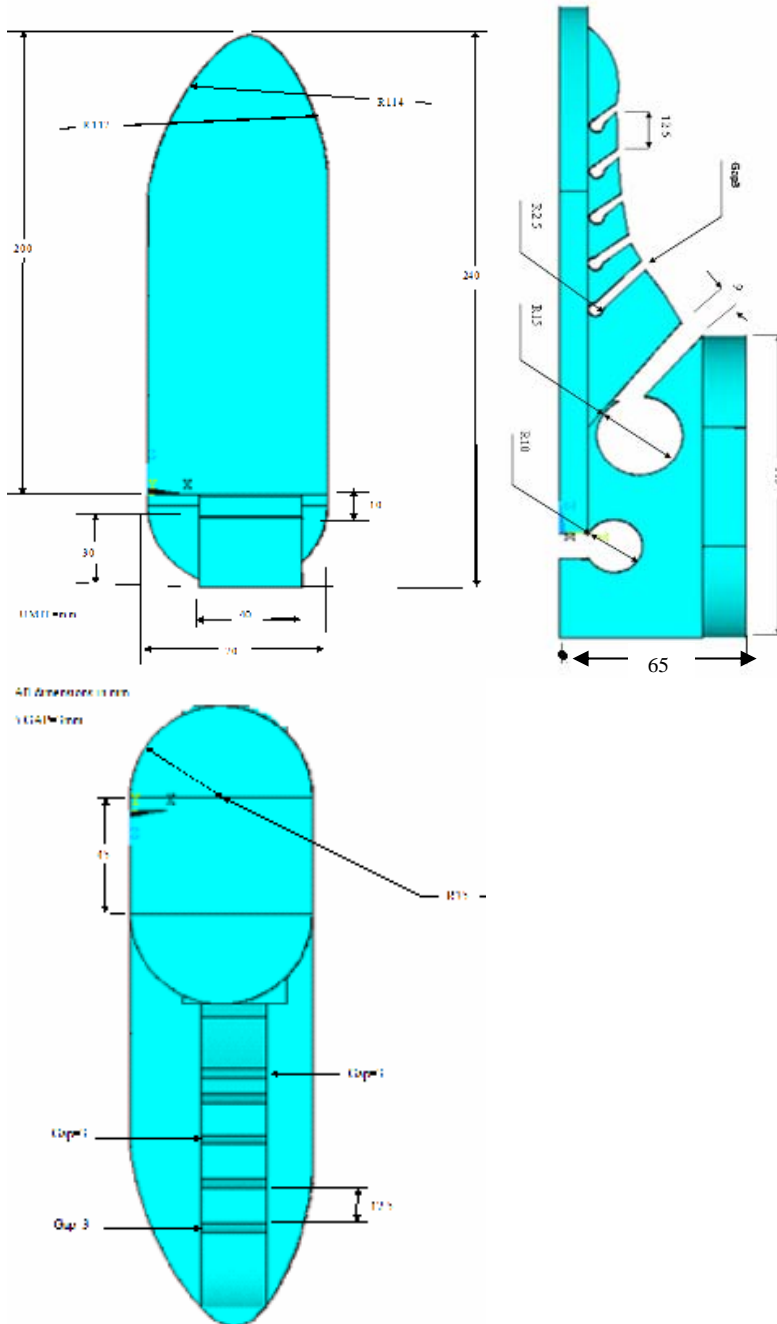

Fig. 1 back, front and top view of NEW foot.

In this paper. After optimizing the design and taking in the consideration the ability for manufacturing the NEW foot, design was drawn and analyzed with the finite element package (ANSYS). [Fig. (1)] The NEW foot was checked with the ANSYS and the development in the shape was continued until the fair shape was reached. A foot was manufactured and first prototype was produced, then simple machining processes were used to get final shape of products. The NEW foot was examined to find out such characteristics as dorsiflexion, dissipating impact energy, life, weight and cost.

4- Modeling of Prosthetic Foot Using ANSYS Software

The finite element method has become a powerful tool for the numerical solution of a wide range of engineering problems. The use of ANSYS-11 to create the finite element model is adopted [8]. The meshing process has been done by choosing the volume and the number of elements in each body, as shown in Figure (2). The number of elements was (10290) elements with total number of nodes of (20580) nodes.

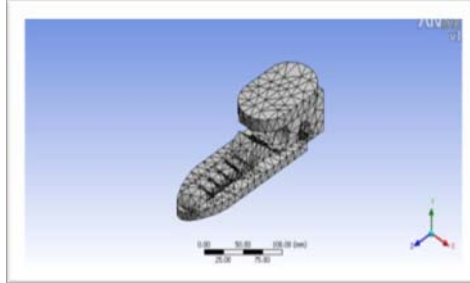

Fig. 2 NEW foot keel with mesh.

5- EXPERIMENTAL WORK

Many experimental tests are recommended for designing and manufacturing the artificial limb. The presented foot is new, and then it is important to examine the design, so that, a full size prototype is manufactured.

The dorsiflexion foot tester, Figure (3) were designed and built specially to examine the foot dorsiflexion. It consists of:

- 1- Frame (wood).
- 2- Shaft (steel).
- 3- Standards disk masses (Cast iron).
- 4- Triangle wood (20°).

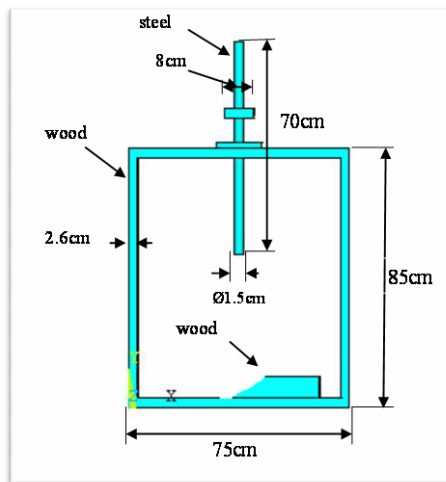

Fig. 3 Dorsiflexion foot tester.

5-1 Fatigue Foot Test

The SACH foot is placed on the fatigue tester in order to obtain the life of the foot. This procedure is applied to the NEW foot to compare between two lives. The load is alternative in order to simulate normal gait.



Fig. 4 Fatigue foot tester of SACH foot and NEW foot.

5-2 Dorsiflexion Test

To complete the dorsiflexion test the triangular wood (20°) must be manufactured and supported with graded ruler, Figures (5). This piece of wood is put in new dorsiflexion foot tester machine. It's replaced under crosshead.



Fig. 5 Dorsiflexion tester of SACH foot and NEW foot.

5-3 Impact Test: Heel Region Properties of Prosthetic Feet

To measure the shock absorption properties of the prosthesis at heel strike and estimate the contact time of the prosthesis with the force plate, measure which prosthesis has the best shock absorption properties at heel strike. To measure the heel region properties of prosthetic feet in response to impact, a pendulum was constructed to mechanically simulate the conditions immediately following initial heel-ground contact during walking.



Fig. 6 Impact foot tester of NEW foot.

6- RESULTS AND DISCUSSION

6-1 Mechanical Properties

The mechanical properties of all material are shown in Table (1).

Table 1 Mechanical properties of polyethylene [9].

MATERIAL	σ_y (MPa)	σ_{ULT} (MPa)	E (Gpa)
POLYETHYLEN	16.52	28.3	1.32

6-2 S-N Curve of Polyethylene

The curve of stress range S (MPa) against N (cycle) is produced.

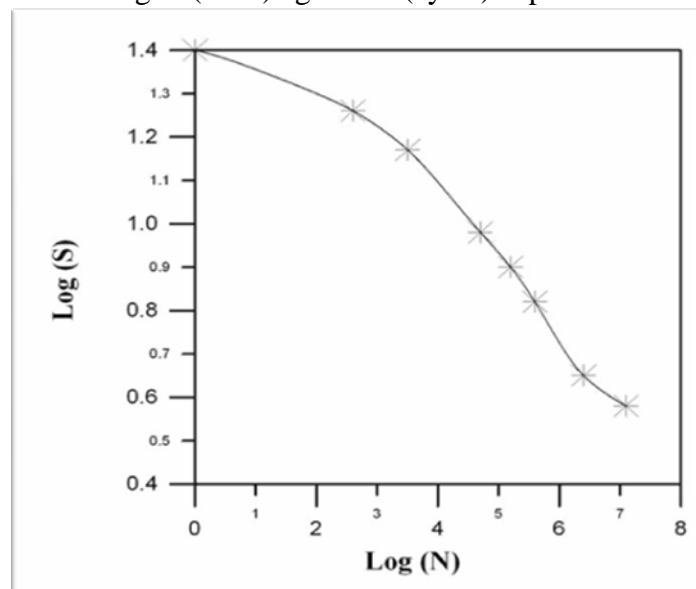

Figure 7 S-N curve for polyethylene [9].

Figure (7) shows the stress with number of cycles, these results are used in ANSYS software to examine a NEW foot life numerically.

6-3 Experimental Results Obtained from Foot

6-3-1 Fatigue Foot Tester Results

In order to determine the validity of the NEW foot fatigue tester in comparison to other testers currently being used, the industry standard SACH foot was tested in one of the test stations in order to determine its time failure. The SACH foot removed from the tester at 896,213 cycles was placed on the tester within a few months of manufacturing. This may indicate the material degradation is a factor in the life expectancy of SACH feet; using of wood and rubber in manufacturing the designed SACH foot. however, further testing would have to be undertaken. The NEW foot failure occurred in one specimen at 2,103,445 cycles as shown in Figure (8).



Fig. 8 Failure region in New foot and SACH foot.

Table 2 Life of different feet.

TYPE OF FOOT	LIFE OF FOOT (CYCLE)
SACH	896,213
NEW FOOT	2,103,445

6-3-2 Dorsiflexion

The dorsiflexion angles were experimentally obtained using a digital camera. The maximum dorsiflexion angles for normal human foot, SACH foot, and NEW foot are tabulated in Table (5-4).

Table 3 Dorsiflexion angle for different types of feet (load =846 N).

TYPE OF FOOT	DORSI-FLEXION ANGLE
Normal Human Foot	4.2°

SACH Foot	6.4°
NEW FOOT	7.8°

6-3-3 Impact for Heel Foot

Table (3) summarizes these results of impact foot. The impact response at heel strike reveal the SACH foot to have the largest peak force, followed in order by the NEW foot.

Table 4 Impact force with different types of feet.

Type of foot	Force read in load cell indicator [kgf]
SACH	9.5
NEW foot	9.82

6-4 Numerical Analysis Results

6-4-1 Static Analysis

The aim of this analysis is to investigate the stresses and deformations of clamped NEW foot with force after assuming that this value is the average of applied load (86kg or 846N). Figure (9) shows the Von-Mises stresses for presented foot is plotted versus foot length where foot toe-off is pointed as zero for the toe off phase. Zero stress will be gradually increase as with length until reaching the location of big hole then it will be decreased because of increasing section dimension, again it will be increasing until reaching the heel hole, then it will be decreased reaching zero at the heel end.

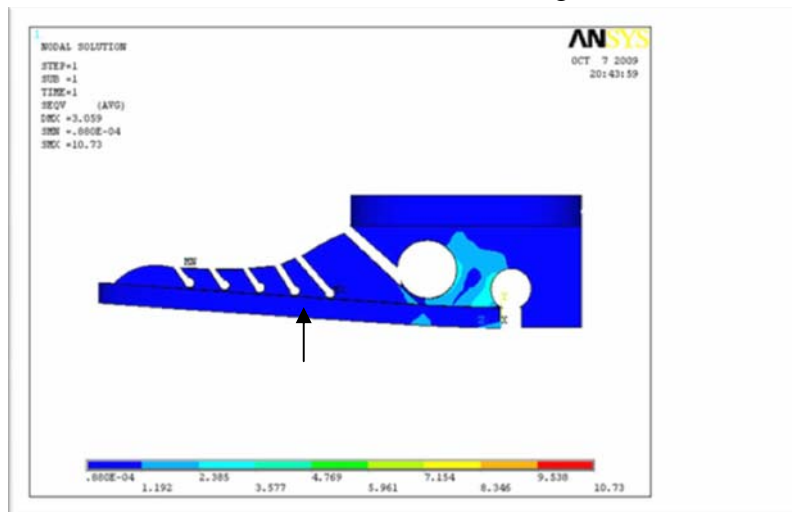

Fig. 9 Von-Mises stress contour of the NEW foot (toe off phase).

6-4-2 Fatigue Analysis.

The aim of this analysis is to investigate the fatigue of clamped NEW foot with force of (846N).

Figure (10) shows the maximum equivalent stress – safety factor for the internal side of the NEW foot. It can be seen from the figure that the maximum equivalent stress – safety factor is located in the heel hole tension side. The current configuration of the fatigue tester is such that it applies a known force using two pneumatic cylinders, one at heel and the other at toe, to simulate walking with a prosthetic foot. The main problem with this concept is that force is not applied during the whole stepping process. But rather is applied at the two extremes of the cycle. By concentrating the ground reaction force to two locations, artificial wear regions are created at the point of application of the heel and toe cylinder.

Recall that a complete gait cycle is the period between the heel strikes of one foot to the next strike of same foot. By testing only at heel strike and toe-off, this phenomenon cannot be simulated as artificial wear points will occur at the location of impact of heel strike and toe off rather than be transmitted throughout the complete stance phase of gait cycle. Cyclic testing is a valid method for evaluating the performance of prosthetic feet. The results obtained from the fatigue testing show that the SACH foot, old SACH and new foot design, which have a significantly stiffer heel bumper with an application force 846N, have the ability to withstand the shearing forces placed upon the prosthetic feet at heel strike without delimitation occurring or cracks developing. It underwent the fatigue process without delimitation occurring and failure was postponed. It appears that the interface of foam / rubber of the heel bumper suffers from distorting proximally at heel strike, this decreases the shear forces in this region. The SACH failed at the end of keel because of degradation in keel manufactured from wood without dorsiflexion in the ankle. The NEW foot failed at more cycles than SACH foot did because it contains multi arc's ankles, and keels, which double dorsiflexion and the material properties for polyethylene, become better than those of rubber foam.

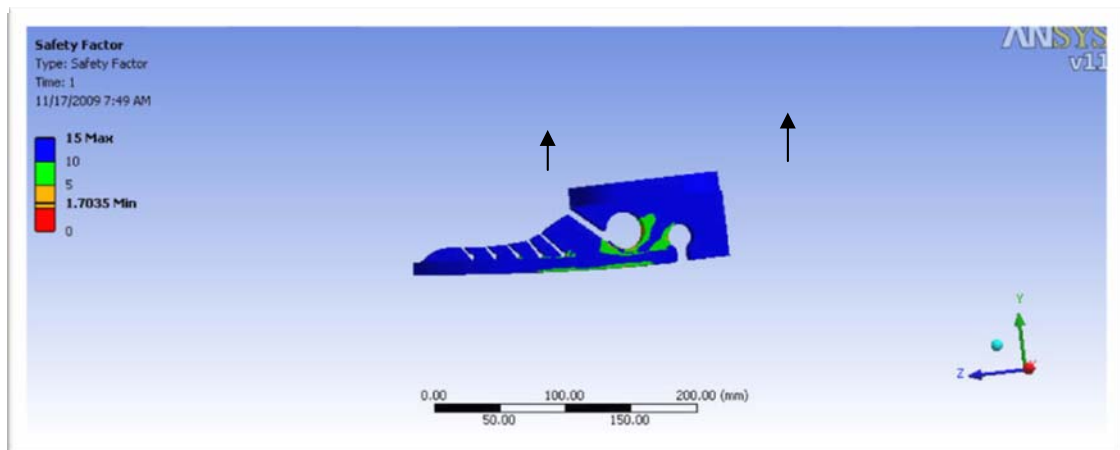

Fig. 10 Maximum equivalent stress contour – Safety Factor of the NEW foot for fatigue load.

7.1 CONCLUSIONS

The aim of this paper is to design a prosthetic foot that incorporates componentry from currently available prosthetic feet. From the results obtained both theoretically and experimentally the following conclusion can be drawn:

1. Using of high density polyethylene (PEHD) in manufacturing the designed NEW foot gives high dorsiflexion angle and long fatigue life but the approximately same impact energy absorption compared with SACH foot.
2. The dorsiflexion angle for the NEW foot is greater than that of the SACH foot, so it may give a bend up to an acceptable limit.
3. Lengthening the supporting keel along the whole length of the NEW foot gives the best stability to gait profile and long fatigue life.
4. The special design with slotted region on the upper side of the NEW foot makes an increment in dorsiflexion angle so it leads to more flexibility in gait profile.

5. The life (cycles) of NEW foot is longer than that of the SACH foot.

7-1 REFERENCES

- 1- **Daher R.L.** "Physical Response of SACH Feet under Laboratory Testing", Bulletin of Prosthetics Research, Vol.10, No.23, pp.4-50, 1975.
- 2- **Wevers, H.W and Durance J.P.** " Dynamic testing of Below –Knee Prosthesis: assembly and Components " J. of Prosthetics and Orthotics International, 11, pp.117-123,1987.
- 3- **R. Deval** "The Seattle Foot" J.oF Orthotics and Prosthetics Vol.40, No.8, pp.17-23, 1986.
- 4- **Toh S. L. , Goh J.C., Tan P. H. and Tay T.E.** "Fatigue Testing of Energy Storing Prosthetics and Orthotics International, 17, pp.180 -188, 1983.
- 5- **Kabra S. and Narayanan R.** " Equipment and Methods for Laboratory Testing of Ankle – Foot Prostheses as Exemplified by the Jaipur Foot " J. of Rehabilitation Research and Development, Vol.28, No.3, pp.23-34 , 1991.
- 6- **Andrew H. Hansen, Michel Sam and Dudley S. Childress** " The Effective Foot Length Ratio: A Potential Tool for Characterization and Evaluation of Prosthetic Feet " , J. of American Academy of Orthotics and Prosthetists , Vol.16, No.2, pp. 41-45, 2004.
- 7- **Anne Schmite** (nee Bans) "Stiffness Analyses for the Design Development of a prosthetic foot ", M.Sc thesis, University of Wisconsin-Madison, 2007.
- 8- **Bathe, K.J.,**1996,"Finite Element Procedure' Prentice Hall International Inc., USA, PP 1037.
- 9- **Kadhim K. Resan Al-Kinani**, "Analysis and Design Optimization of Prosthetic Below Knee" Ph.D., College of Engineering, Technology University, 2007.