

## Mechanical Properties of Tempered Nanobainite Steel

**Dr. Dhafir S. Al-Fattal**

Machines & Equipments Engineering Department, University of Technology/ Baghdad  
Email: [dsalfattal@yahoo.co.uk](mailto:dsalfattal@yahoo.co.uk);

**Najmuldeen Y. Mahmood**

Machines & Equipments Engineering Department, University of Technology/ Baghdad

Received on: 12/12/2011 & Accepted on: 24/6/2012

### ABSTRACT

The mechanical properties of 62 SiMnCr 4 steel transformed isothermally at 280°C for 5-hours were investigated. The hardness of nanobainite steel was equivalent to tempered martensite steel. The hardness decreases significantly at high tempering temperatures in excess of 500°C. Yield strength of about 2GPa and ultimate tensile strength of 2.3GPa have been achieved for nanobainite steel. Furthermore, the high strength is frequently accompanied by relatively good percentage elongation of 8.25%. The strength decreases and the ductility increases with increasing tempering temperature. Nanobainite steel has a high charpy impact energy of 170 J which decreases linearly with increasing tempering temperature. Fatigue strength of nanobainite steel is higher than tempered martensite, its decreases with increasing tempering temperature.

**Keyword:** Nanobainite steel; Tempering; Mechanical Properties

### الخواص الميكانيكية لصلب النانو بايانايت والمراجع حرارياً

#### الخلاصة

تم دراسة الخواص الميكانيكية للصلب 62 SiMnCr 4 المتحول بدرجة حرارية ثابتة هي 280°C ولمدة خمس ساعات الى طور البايانايت الدقيق جداً (Nanobainite). ان صلادة البايانايت كانت مكافئة لصلادة المارتنسايت المراجع (Tempered martensite). تتناقص صلادة البايانايت بشكل واضح اثناء المراجعة الحرارية في درجات الحرارة التي تتجاوز 500°C. تم الحصول على مقاومة خضوع ومقاومة شد بحدود (2 GPa) و (2.3 GPa) على التوالي، وإضافة لهذه المقاومة العالية فقد تم الحصول على نسبة استطالة جيدة نسبياً (8.25%). تتناقص المقاومة وتزداد المطيلية بزيادة درجة حرارة المراجعة. للبايانايت طاقة صدمة عالية بحدود (170 J) وتتناقص خطياً بزيادة درجة حرارة المراجعة. لصلب البايانايت مقاومة كلال اعلى من المارتنسايت المراجع وتتناقص مقاومة الكلال مع زيادة درجة حرارة المراجعة.

## INTRODUCTION

Bainite is a non-equilibrium transformation product of austenite which evolves by cooling at rates such that the diffusion-controlled transformation such as pearlite are not possible, yet the cooling is sufficiently slow to avoid the diffusionless transformation into a thermal martensite. Bainitic microstructures are generally described as non-lamellar aggregates of carbides and plate-shaped ferrite [1].

In addition, this microstructure is similar to pearlite, since the two microstructures consist ferrite and cementite, but the bainite microstructure appears in transmission electronic microscopy very smooth compared with pearlite, and differs in the method of growth. The ferrite nucleates first and forms elongated grains known as laths. The cementite is then deposited between these laths at higher temperatures and within them at lower temperatures [2].

A new generation of bainitic steels has recently been developed using detailed phase transformation theory for the bainite reaction. The steels have a simple metallurgy, which can be summarized as follows [3];

- i. The need for low bainitic and martensitic transformation temperatures ( $B_S$  and  $M_S$  respectively) both to maximize the fraction of bainite and to reduce the scale of the microstructure;
- ii. The precipitation of cementite is avoided by alloying with silicon; cementite is a brittle phase in high strength steels;
- iii. In spite of the low transformation temperatures, the steel is designed to achieve the required bainitic microstructure in realistic time-scales during isothermal transformation. Furthermore, the hardenability is engineered so that phases such as ferrite and pearlite are avoided during cooling from the austenitization temperature.

The hardness of the nanobainite steel can be as high as 650 HV [4-6], with tensile strength in excess of 2200 MPa and ductility in the range (5–30) %. These values are achieved by forming bainite at the lowest transformation temperatures [3,6]. Much work has been carried out on nanobainite steel but most of it is concerned with the high hardness and strength of this material which found some applications in industry. However, very few investigations have been traced for fatigue strength [7], and none for impact energy. Besides, the effect of tempering on the mechanical properties of nanobainite steel is lacking. The work reported in references [6, 8] were two of the few which studied the effect of tempering on the hardness of nanobainite steel.

This work attempts to provide the lacking information concerning a wide range of mechanical properties of nanobainite steel. Mainly the effect of tempering will be studied in an attempt to modify the alloy based on the fine structure, for purposes other than those currently in commercial use.

## EXPERIMENTAL PROCEDURE

Round bars of 62 SiMnCr 4 steel (DIN 1.2101) with a diameter of 20mm were used in this study. The chemical composition of the steel is shown in Table (1).

The bars were machined into cylindrical tensile specimens, square charpy V-notch impact specimens and cylindrical fatigue specimens. The geometry and dimensions of the specimens are shown in figure (1).

The specimens were austenitized at 850°C for 30min., rapidly cooled in a salt bath (65% Potassium hydroxide and 35% Sodium hydroxide) and maintained at 280°C for 5-hours, air cooled and then tempered at three different temperatures (350, 550 and 650°C) for 4-hours. Other specimens were austenitized at 850°C for 30min., directly quenched in oil, tempered at 300°C for 2-hours (DQT).

Temperatures for the start of phase transformation to martensite and bainite ( $M_s$  and  $B_s$ ) and the time transformation temperature (T.T.T.) diagram for the steel were determined using MUCG-73 program [9]. The input data to the program is only the chemical composition of the steel and figure. (2) Shows the Time-Transformation-Temperature (TTT) diagram for the steel used in this investigation.  $M_s$  and  $B_s$  were found to be 240 and 380°C, respectively.

Samples for optical and scanning probe microscopy were ground using different grades of wet silicon carbide papers (260, 500, 800, 1000, 1200 and 1500). The samples were then polished using diamond paste (1.5 micron). Distilled water and alcohol were used to clean the samples in succession. Etching was carried out with Nital (2% HNO<sub>3</sub> in alcohol) followed by washing with water and alcohol.

Vickers hardness tests were carried out by (HVS1000) machine with a load of 9.8 N applied for 20 seconds and each hardness value is an average of three tests. A tensile machine (ITT) with a 50KN load cell and a crosshead speed of (1 mm/min) was used in all the experiments. Brook's impact machine was used in all the impact experiments. A rotating bending fatigue machine type Hi-Tech was used to carry out the fatigue testing. A speed of 6000 rpm was available with a capability of applying different stress levels with zero mean stress (stress ratio equal to (-1)). All the tests were performed at room temperature and in laboratory air. The outer surface at the reduced section of all fatigue specimens was prepared by mounting on a lathe to rotate the specimen about the central axis and then polishing by hand through the following steps:

1. The surface of the specimens was smoothed using different wet silicon carbide papers (260, 500, 800, 1000, 1200 and 1500).
2. The specimens were polished using diamond paste (1 $\mu$ m and then 0.25 $\mu$ m).
3. Distilled water was used to clean the specimens followed by washing with alcohol.

## RESULTS AND DISCUSSION

### Microstructure

Figure (3) shows optical micrographs (OM) for two samples; the directly quenched in oil and the isothermally hardened (IH) for 5-hours. At this magnification, a little difference is observed in the microstructure, except the finer scale of the microstructure for the isothermally hardened material for 5-hours.

More details about the grain size can be revealed by scanning probe microscopy (SPM), figures (4) and (5). The average diameter of grains for directly quenched and isothermally hardened for 5 hours are 572.41 nm and 92.23 nm respectively. It has been suggested [10] that the average scale of grains for nanostructured bainitic steel is in the range (20-100) nm and has been achieved in this study in the isothermally hardened for 5 hours condition.

### Mechanical properties

The results of mechanical properties for the directly quenched and tempered (DQT) and isothermally hardened (IH) in salt bath and the three tempering temperatures conditions are listed in Table (2). Hardness of IH is equivalent to hardness of DQT steel. The hardness of isothermally hardened is similar to the hardness of nanobainite reported in the literatures [3-8]. Nanobainite steel is insensitive to tempering temperature less than 500°C. However, the hardness decreases significantly at high tempering temperature in excess of 500°C as showing in figure (6).

Tensile strength of IH is higher than DQT and the first has higher ductility (measured as % elongation and % reduction in area) as compared with DQT steel as showing in figure (7). The improvements in the mechanical properties of nanobainite steel were 20% in tensile strength, 15% in yield strength, 41% in percentage elongation and 9% in percentage reduction in area. Besides, nanobainite steels are produced at low transformation temperatures without the need for rapid cooling rates associated with martensitic steels.

The detrimental effects of rapid cooling on the properties of hardened steels are well documented [11] which include high residual stresses, brittleness, distortion and the probability of the development of quenching cracks especially in large sections. Therefore, nanobainite steels, which are produced without any rapid cooling, are ideal alternatives in material design when a combination of higher strength with good ductility is required.

Generally, strength decreases with tempering treatments, figure (8). In contrast, ductility increases with tempering temperature as shown in figure. (9). However, the decrease in tensile strength and the increase in ductility are more significant at tempering temperatures above 500°C.

Impact energy of IH steel is much higher than DQT steel, which highlighted the high toughness of then nanobainite phase as compared with tempered martensite. The improvement in impact energy of nanobainite steel was 325%. Tempering this nanobainite structure leads to a decrease in impact energy as shown in figure (10). The decrease in impact energy was about 12.5J per 100°C increase in tempering temperature.

Figure (11) shows the S-N curves of all conditions. It can be observed that the fatigue resistance and the fatigue endurance ( $\sigma_e$ ) of nanobainite steel (IH) is higher than tempered martensite (DQT) because the first has higher strength than the second. Quenched and tempered steels have been used in many applications but the embrittlement of martensite is a main cause of failures. It can be also observed in this figure that the fatigue resistance and the fatigue endurance decreases with increasing tempering temperature.

Table (3) shows the fatigue endurance of all groups. The table also shows the ratio of fatigue endurance to ultimate tensile strength ( $\sigma_e / \sigma_U$ ) and the % drop in fatigue endurance due to tempering. The striking point in this table is the ratio ( $\sigma_e / \sigma_U$ ) which is 0.58 for all conditions. This is not far from the ratio of 0.5 proposed in the literature [12].

It can be observed that at 350°C, the fatigue endurance dropped by 7%. However, tempering at 550°C leads to a decrease in the fatigue endurance by 17%. In this case, the fatigue endurance is similar to the fatigue endurance of the

tempered martensite (DQT). This does not mean that the properties of tempered martensite are the same as the properties of tempered nanobainite because tempered nanobainite at 550°C has higher ductility and impact energy. The decrease of fatigue endurance with tempering temperature continues at 650°C to become 28%. Figure (12) summarized the effect of tempering temperature on the fatigue endurance of nanobainite structure. It can be seen that the drop in fatigue endurance is more pronounced at higher temperatures of 550°C and 650°C.

Figure (13) clarifies the dependence of the fatigue endurance on the tensile strength. It is clear that the fatigue endurance rises with increasing tensile strength linearly. The slope of this linear relation is 0.58 which is the ratio ( $\sigma_e / \sigma_U$ ).

As a final note, nanobainite steels have a combination of properties including tensile strength, impact resistance and fatigue resistance which make nanobainite steels superior to tempered martensite.

### **CONCLUSIOS**

The low-temperature bainitic steel is obtained in 62 SiMnCr 4 steel by isothermal transformation at 280°C for 5 hours after austenitizing at 850°C for 30min. and the following conclusions were drawn:

1. The hardness of untempered nanobainite steel is almost equivalent to the hardness of tempered martensite (tempering temperature 300°C).
2. The hardness of nanobainite steel decreases as the tempering temperature increases. This is only significant at high tempering temperature in excess of 500°C.
3. The tensile strength, yield strength, percentage elongation, percentage reduction in area, impact energy and fatigue strength of untempered nanobainite steel are higher than those of tempered martensite.
4. The tensile strength, yield strength, impact energy and fatigue strength of nanobainite steel decreases as the tempering temperature increases.
5. The percentage elongation and percentage reduction in area of nanobainite steel increases as tempering temperature increases.
6. The tensile strength of the untempered nanobainite structure is in excess of 2 GPa, its impact energy is 170 J and its fatigue endurance is more than 1 GPa which make this structure superior in comparison with tempered martensite structure.

### **ACKNOWLEDGEMENTS**

The authors are grateful to the Department of machines and Equipments Engineering/University of Technology / Baghdad / Iraq, for all the support during the course of this research. They are also grateful to Dr. AiadMorad (Head of Mechanical Engineering Department/Nahrain University) for help and assistant. Special thanks are also due to Dr. Abdul Kareem Al-Samraei (Baghdad University / Science College / Chemical Department) for his help to complete the SPM results.

### **REFERENCES**

- [1].Sherif M. Y. "Characterization and Development of Nanostructured, Ultrahigh Strength, and Ductile Bainitic Steel" Ph.D. Thesis, Department of Materials Science and Metallurgy, University of Cambridge, 2006

[2]. Posoe K. J. “An Introduction to the Properties of Engineering Material”, 3<sup>rd</sup> Edition, VNR Company, London, 1978

[3]. Garcia-Mateo C., Caballero F. G. and Bhadeshia H. K. D. H. “Mechanical Properties of Low-Temperature Bainite” Materials Science Forum, vols. 500-501, pp(495-502), 2005

[4]. Bhadeshia H. K. D. H. “Nanostructure Bainite”, Royal Society,A466, pp.(14), 2009

[5]. Garcia-Mateo C., Caballero F. G., and Bhadeshia H. K. D. H. “Development of Hard Bainite”, ISIJ International, Vol.43, No.8, pp.(1238-1243), 2003

[6].Caballero F. G., Bhadeshia H. K. D. H., Mawella K. J. A., Jones D. G., and Brown P. “Very Strong Low Temperature Bainite”, Materials Science and Technology, Vol.18, pp.(279-284), 2002

[7].Peet M. J., Hill P., Rawason M., Wood S., and Bhadeshia H. K. D. H. “Fatigue of Extremely Fine Bainite” Material Science and Technology Vol.27, No.1,pp (119-123), 2011

[8].Garcia-Mateo C., Peet M., Caballero F. G., and Bhadeshia H. K. D. H. “Tempering of hard mixture of bainitic ferrite and austenite” Materials Science and Technology, Vol.20, 814-818, 2004

[9].[www.msm.ac.uk/map/steel/programs/mucg73.html](http://www.msm.ac.uk/map/steel/programs/mucg73.html)  
 “Phase Transformation & Complex Properties Research Group” Bhadeshia H. K. D. H. in Materials Algorithms Project. University of Cambridge, Department of Materials Science and Metallurgy, UK.

[10].Bhadeshia H.K.D.H. & Honeycombe S. R. “Steel, Microstructure and Properties”, 3<sup>rd</sup> Edition, Elsevier Ltd., pp.(27-31), 2006

[11].ASM International, Vol.4, “Heat Treating”, pp. (160-291), 1991

[12].Yung-Li L., Jwo Pan, Richard B. Hathaway and Mark E. Barkey “Fatigue Testing and Analysis (Theory and Practice)” Elsevier Butterworth-Heinemann Ltd., Printed in USA, pp(131-134), 2005

**LIST OF TABLES**

**Table (1) Chemical composition.**

<b>Element</b>	<b>wt %</b>	<b>Element</b>	<b>wt %</b>	<b>Element</b>	<b>wt %</b>
<b>C</b>	0.58	<b>Co</b>	0.06	<b>Ni</b>	0.06
<b>Si</b>	1.03	<b>Al</b>	0.009	<b>Cu</b>	0.08
<b>Mn</b>	1.05	<b>W</b>	0.001	<b>P</b>	0.01
<b>Cr</b>	0.49	<b>V</b>	0.001	<b>S</b>	0.018
<b>Mo</b>	0.03	<b>Ti</b>	0.09	<b>Fe</b>	remainder

Table (2) Mechanical Properties.

Condition	Hardness (HV)	UTS <sup>a</sup> (MPa)	YS <sup>b</sup> (MPa)	%El <sup>c</sup>	%R <sub>A</sub> <sup>d</sup>	Impact Energy (J)
DQT	631	1900	1750	5.838	5.088	40
IH	655	2285	2010	8.25	5.561	170
IHT1 <sup>e</sup>	638	2135	1800	10.625	6.059	129
IHT2 <sup>f</sup>	575	1885	1550	12.5	8.03	100
IHT3 <sup>g</sup>	408	1666	1340	15	9.99	89

a: Ultimate Tensile Strength; b: Yield Strength; c: percentage elongation; d: percentage reduction of area; e, f and g: Isothermal Hardened with Tempering at 350, 550 and 650°C respectively.

Table (3) Drop in fatigue endurance duo to tempering.

Group	$\sigma_e$ (MPa)	$\sigma_e / \sigma_U$	Drop (%)
DQT	1100	0.58	----
IH	1320	0.58	----
IHT1	1230	0.58	7
IHT2	1100	0.58	17
IHT3	960	0.58	28

LIST OF FIGURES

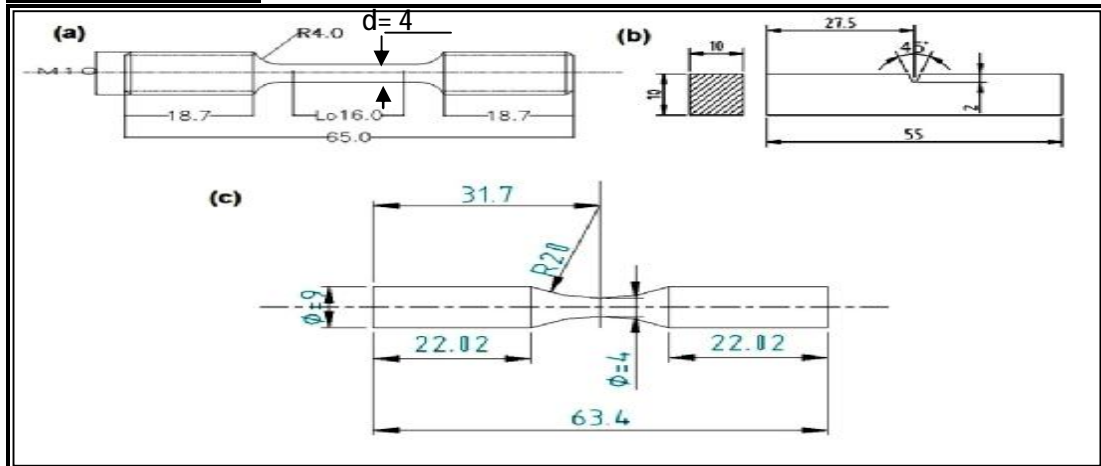

Figure (1) Geometry and dimensions of tests specimens; (a) Tensile specimen; (b) Impact specimen; (c) Fatigue specimen. (b) (All dimensions in millimeter).

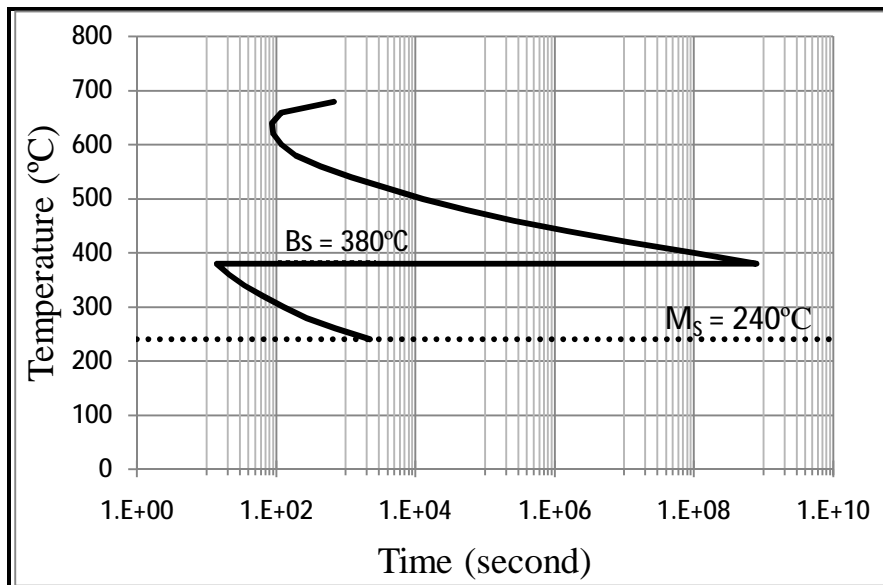

Figure (2) TTT diagram of the steel used.

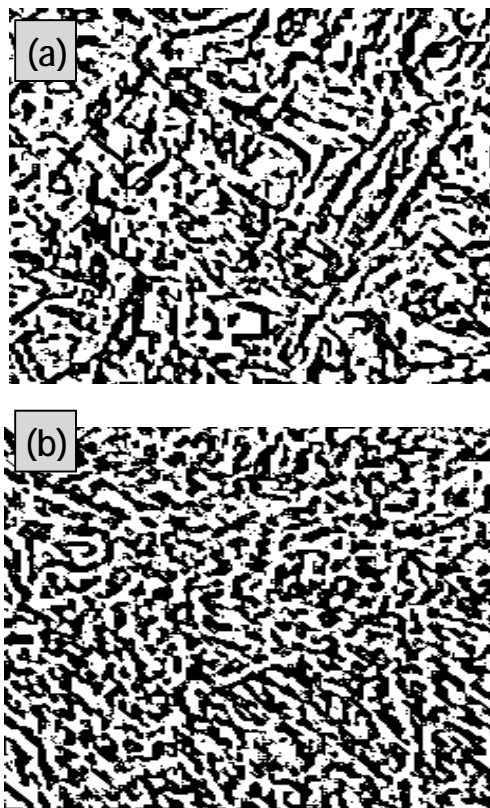

Figure (3) Optical micrographs with 1600X magnification;  
(a) Directly quenched in oil;  
(b) Isothermally hardened for 5-hours.



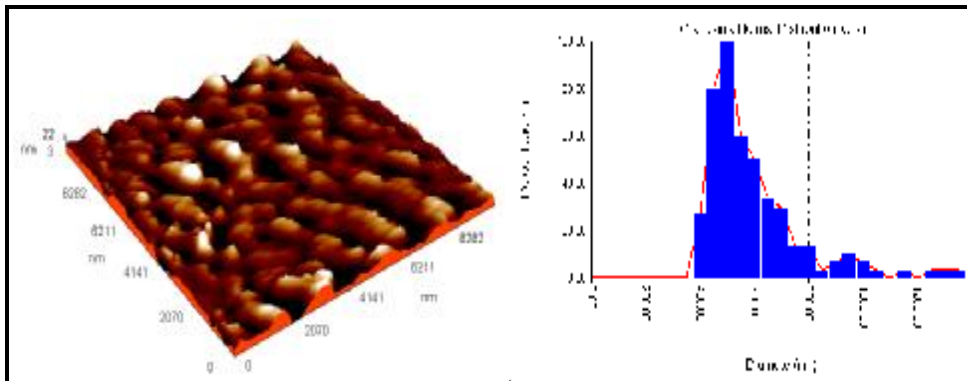

Figure (4) SPM result of directly quenched sample.

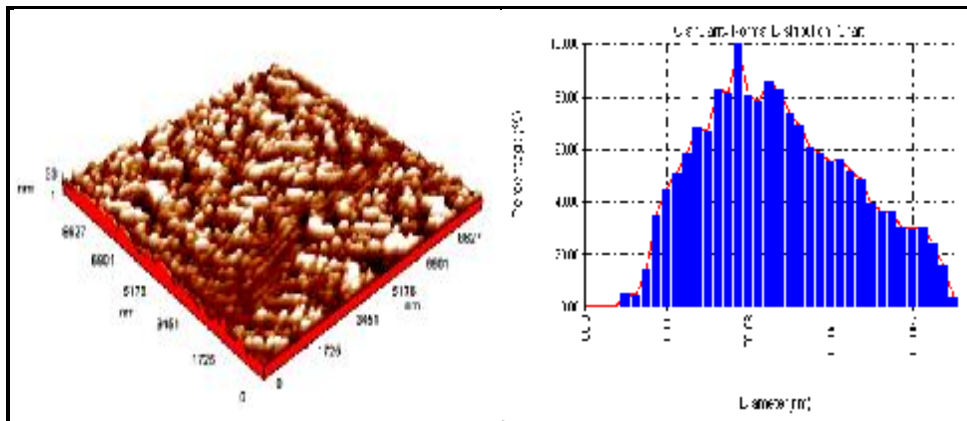

Figure (5) SPM result of IH sample.

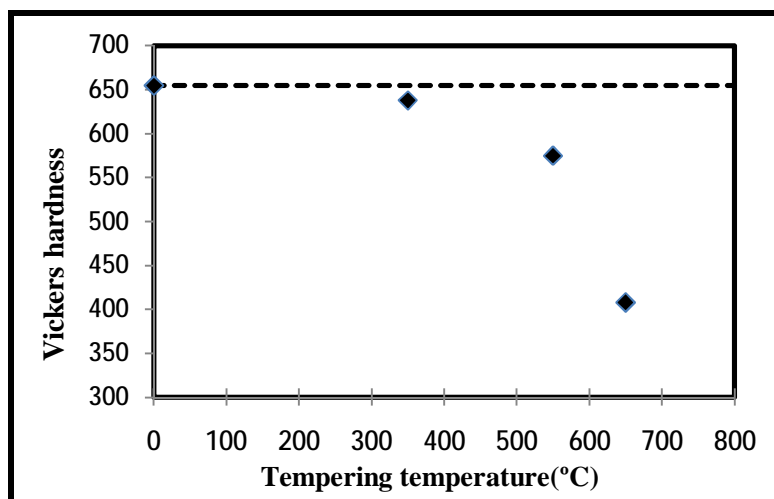

Figure (6) Change of hardness with tempering; the horizontal line represents the hardness without tempering.

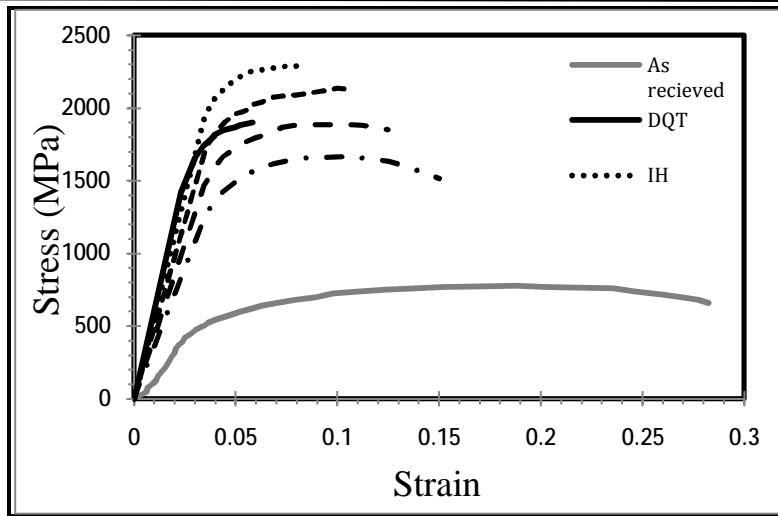

Figure (7) Stress-Strain curves.

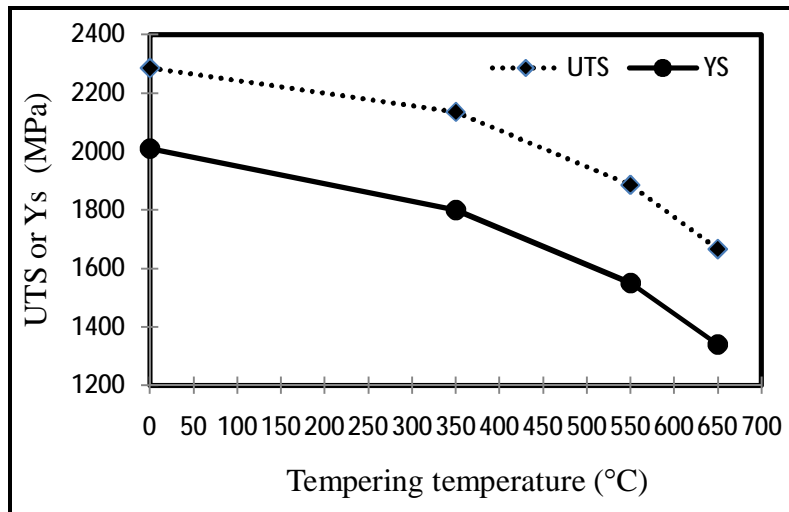

Figure (8) Variation of (UTS and YS) with tempering temperature.

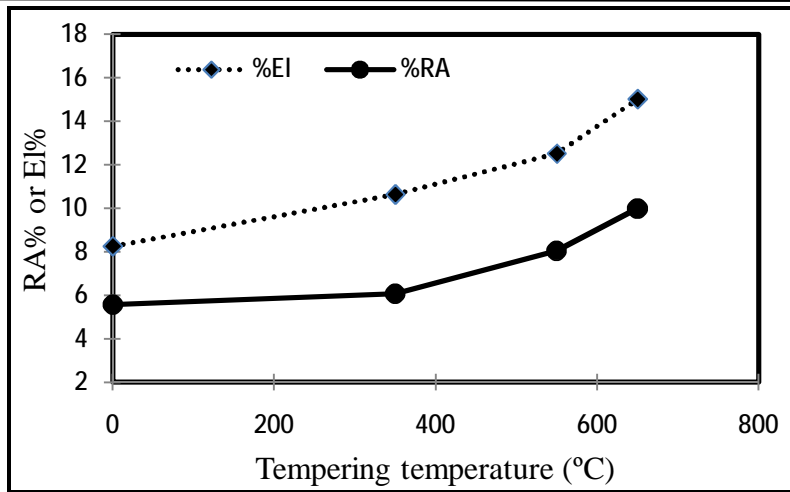

Figure (9) Variation of (%EI and %RA) with tempering temperature.

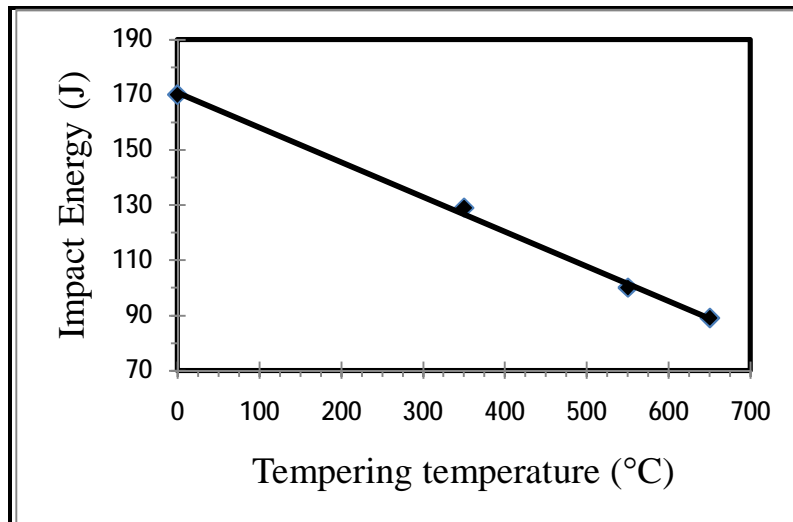

Figure (10) The change of impact energy with tempering temperature.

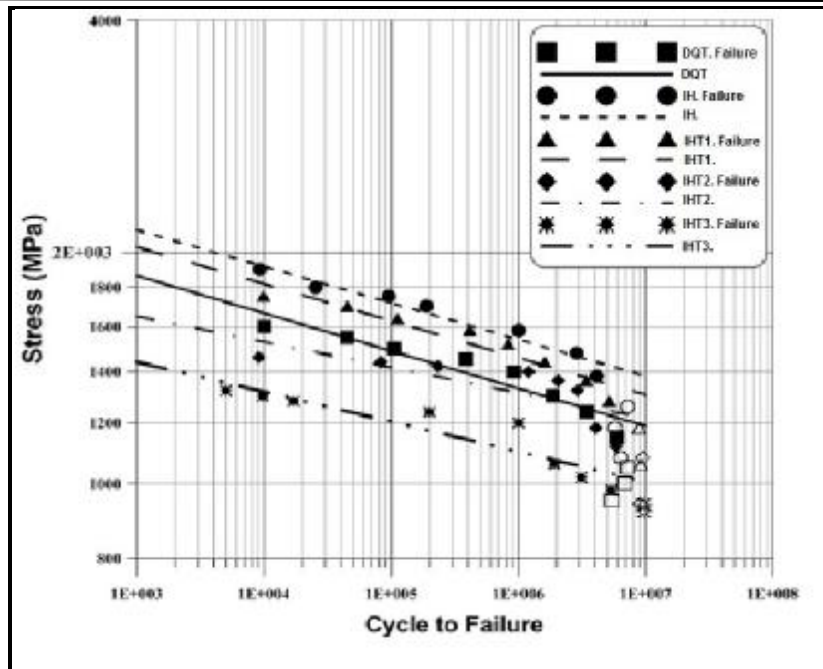

Figure (11) S-N curves of all groups (log scale). All open symbols represent specimens without failure.

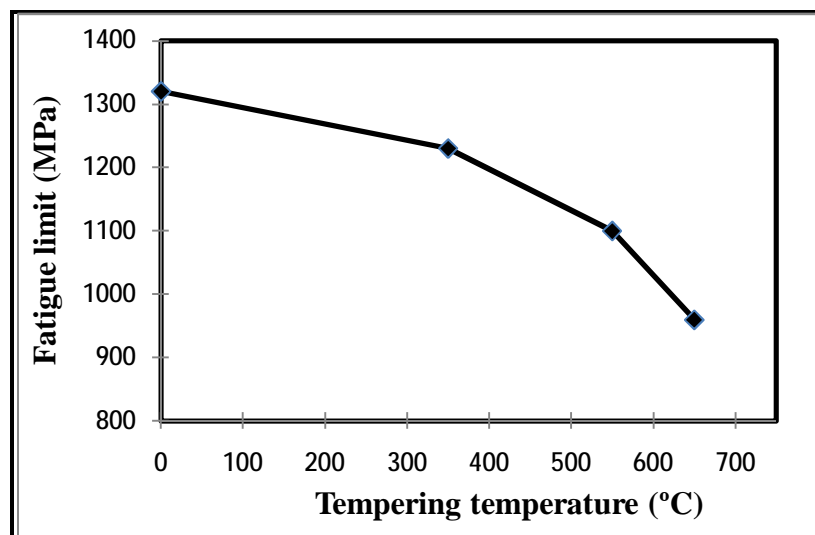

Figure (12) Change of fatigue endurance with tempering temperature.

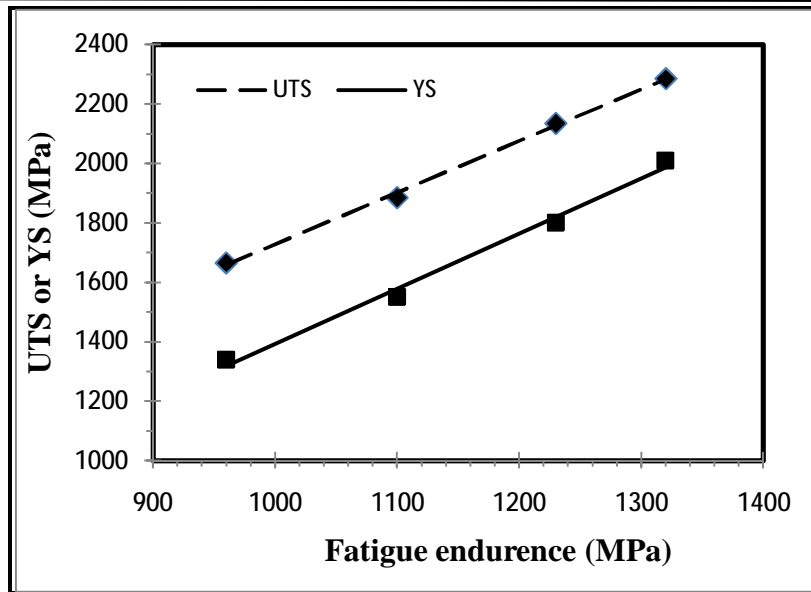

Figure (13) Change of fatigue endurance with the UTS and YS.